

Versatile and Powerful

- Minimum 180 in-lb torque in a compact package.
- For damper areas up to 45 sq. ft*, Q Series- 35 sq. ft*



All Actuators have BDCM

AM Series - At A Glance

		<i>AMB(X)24-3 (p. 213)</i>	<i>AMB24-3-S (p. 213)</i>	<i>AMX24-3-T (p. 213)</i>	<i>AMB24-3-T N4(H) (p. 215)</i>	<i>AMX120-3 (p. 217)</i>	<i>AMB(X)24-SR (p. 219)</i>	<i>AMX24-SR-T (p. 219)</i>	<i>AMB24-SR-T N4(H) (p. 221)</i>	<i>AMX120-SR (p. 223)</i>	<i>AMB(X)24-MFT (p. 225)</i>	<i>AMX24-MFT-T N4(H) (p. 227)</i>	<i>AMC24-MFT (p. 229)</i>	<i>AMX24-MFT95 (p. 231)</i>	<i>AMX24-PC (p. 233)</i>	<i>AMQB(X)24-1 (p. 235)</i>	<i>AMQB(X)24-MFT (p. 237)</i>	<i>AMX24-LON (p. 239)</i>
Basic Product (B)		•	•				•				•					•	•	
Flexible Product		•		•		•	•	•		•	•	•	•	•	•	•	•	•
Torque	180 in-lb [20 Nm]	•	•	•		•	•	•		•	•	•	•	•	•			•
	160 in-lb [16 Nm]				•				•			•						
	140 in-lb [16 Nm]																•	•
Angle of Rotation	95 degrees	•	•	•	•	•	•	•	•	•	•	•	•	•	•	•	•	•
Power Supply	24 VAC/DC	•	•	•	•		•	•	•		•	•	•	•	•	•	•	•
	100 to 240 VAC					•				•								
Control Input	On/Off																•	
	On/Off, Floating Point	•	•	•	•	•												
	2 to 10 VDC (4 to 20mA)						•	•	•	•								
	Multi-Function Technology										•	•	•					•
	0 to 135 Ohm													•				
	0 to 20V Phasecut														•			
Feedback	LonWORKS®																	•
	None	•	•	•	•	•											•	
	2 to 10 VDC						•	•	•	•					•			
	Variable (0 to 10 VDC)										•	•	•	•				•
Running Time	95 seconds	•	•		•		•	•										
	Adj. 7 to 20 seconds																•	•
	Adj. 95 to 300 seconds (150)	•		•		•		•		•	•			•	•			
	150 seconds										•	•						•
Wiring	Plenum Rated Cable	•					•			•			•	•	•	•	•	•
	Appliance Rated Cable		•			•				•								
	Terminal Strip			•	•			•	•			•						
	Conduit Fitting	•	•			•	•			•	•		•	•	•	•	•	•
Auxiliary Switch	Built-In		•															
	Add-On	•	•	•	•	•	•	•	•	•	•	•	•	•	•	•	•	•

Installation and Operation... (page 269).

*Based on 4 in-lb/ft² damper torque loading. Parallel blade. No edge seals.

A CLOSER LOOK...

- Brushless DC Motor for Added Accuracy and Controllability.
- Cut Labor Costs with Simple Direct Coupling.
- Self-Centers on 1/2", 3/4", and 1.05" Jackshafts with Standard Clamp.
- Check Damper Position with Clear Position Indicator.
- Don't Worry about Actuator Burn-Out; Belimo is Overload Proof throughout Rotation.
- Enjoy Added Flexibility with Easy Mechanical Stops to Adjust Angle of Rotation.
- Need to Change Control Direction? Do it easily with a Simple Switch.
- Easily Accessible Manual Override Button helps you Pre-Tension Damper Blades.
- Fully Adjustable Built-In Auxiliary Switch (AMB24-3-S).
- Auxiliary Switch and Feedback Potentiometer Add-Ons Mount Directly on Clamp, Includes Conduit Connector.
- Standard 3ft Plenum Rated Cable and Conduit Connector Provided on Basic Models.
- Added Flexibility to Select Clamp, Electrical Connection, and Running Time to fit your Specific Application with Belimo's New Flexible Line of Actuators.



The Belimo Difference

- **Customer Commitment.**
Extensive product range. Application assistance.
Same-day shipments. Free technical support. Five year warranty.
- **Low Installation and Life-Cycle Cost.**
Easy installation. Accuracy and repeatability.
Low power consumption. No maintenance.
- **Long Service Life.**
Components tested before assembly. Every product tested before shipment.
30+ years direct coupled actuator design.

M40024 - 05/10 - Subject to change. © Belimo Aircontrols (USA), Inc.

AMB(X)24-3(-S)(-T)

On/Off, Floating Point, Non-Spring Return, 24 V

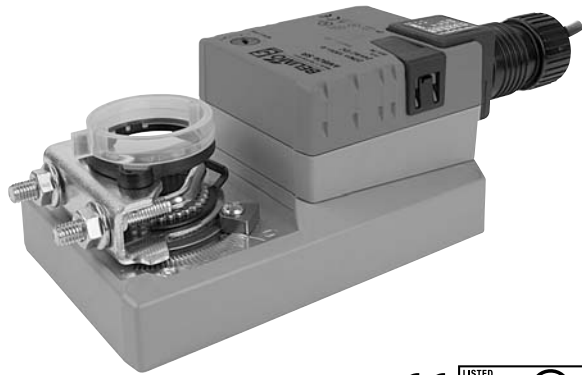

Technical Data	AMB(X)24-3(-S)(-T)
Power supply	24 VAC ± 20% 50/60 Hz 24 VDC ± 10%
Power consumption	2.5 W (0.5 W)
Transformer sizing	5.5 VA (Class 2 power source)
Electrical connection	3 ft, 18 GA plenum rated cable 3 ft, 18 GA appliance rated cable (-S) 1/2" conduit connector protected NEMA 2 (IP54)
Overload protection	electronic throughout 0 to 95° rotation
Control	on/off, floating point
Input impedance	600 Ω
Angle of rotation	max. 95°, adjust. with mechanical stop
Torque	180 in-lb [20 Nm]
Direction of rotation	reversible with switch
Position indication	reflective visual indicator (snap-on)
Manual override	external push button
Auxiliary switch (-S models)	1 x SPDT, 3A (0.5A) @ 250 VAC adj. 0 to 100%, UL approved
Running time	95 seconds, constant independent of load
Humidity	5 to 95% RH non condensing (EN 60730-1)
Ambient temperature	-22°F to 122°F [-30°C to 50°C]
Storage temperature	-40°F to 176°F [-40°C to 80°C]
Housing	NEMA 2, IP54, UL enclosure type 2
Housing material	UL94-5VA
Agency listings†	cULus acc. to UL 60730-1A/-2-14, CAN/CSA E60730-1:02, CE acc. to 2004/108/EEC and 2006/95/EC
Noise level	<45dB(A)
Servicing	maintenance free
Quality standard	ISO 9001
Weight	2.2 lbs [1000 Kg] AMB24-3 2.4 lbs [1050 Kg] AMB24-3-S

AMB(X)24-3-T	
Electrical connection	screw terminal (for 26 to 14 GA wire) unprotected (NEMA 1/IP20)

†Rated Impulse Voltage 800V, Type of action 1, (1.B for -S version), Control Pollution Degree 3.

Torque min. 180 in-lb for control of damper surfaces up to 45 sq ft.

Application

For on/off and floating point control of dampers in HVAC systems. Actuator sizing should be done in accordance with the damper manufacturer's specifications.

The actuator is mounted directly to a damper shaft up to 1.05" in diameter by means of its universal clamp, self-centered default. A crank arm and several mounting brackets are available for applications where the actuator cannot be direct coupled to the damper shaft.

Operation

The actuator is not provided with and does not require any limit switches, but is electronically protected against overload. The anti-rotation strap supplied with the actuator will prevent lateral movement.

The AM... series provides 95° of rotation and a visual indicator indicates position of the actuator. When reaching the damper or actuator end position, the actuator automatically stops. The gears can be manually disengaged with a button on the actuator cover.

The AM...24-3... actuators use a sensorless brushless DC motor, which is controlled by an Application Specific Integrated Circuit (ASIC). The ASIC monitors and controls the actuator's rotation and provides a digital rotation sensing (DRS) function to prevent damage to the actuator in a stall condition. Power consumption is reduced in holding mode.

The AM...24-3-S version is provided with 1 built-in auxiliary switch. This SPDT switch is provided for safety interfacing or signaling, for example, for fan start-up. The switching function is adjustable 0 to 95°. The auxiliary switch is double insulated so an electrical ground connection is not necessary.

Add-on auxiliary switches or feedback potentiometers are easily fastened directly onto the actuator body for signaling and switching functions.

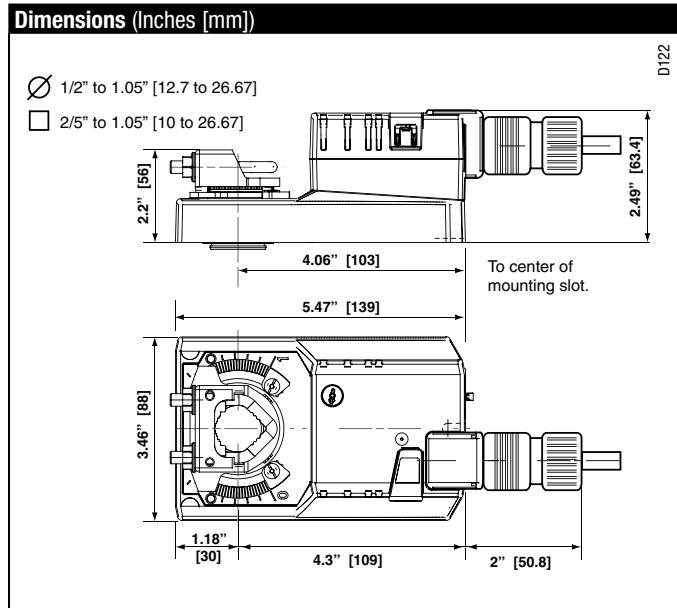

M40024 - 05/10 - Subject to change. © Belimo Aircontrols (USA), Inc.

Accessories

K-SA	Reversible Clamp
ZG-100	Universal Mounting Bracket
ZG-101	Universal Mounting Bracket
ZG-103	Universal Mounting Bracket
ZG-104	Universal Mounting Bracket
Z-SMA	AM/SM to AM Retrofit Mounting Bracket
ZG-NMA	Crank arm Adaptor Kit
AV8-25	Universal Shaft Extension
ZG-JSA (-1, 2,3)	Jackshaft Adaptors for Hollow Jackshafts
ZS-T	Terminal Cover for NEMA 2
ZS-100	Weather Shield - Steel
ZS-150	Weather Shield - Polycarbonate
ZS-260	Explosion Proof Housing
ZS-300 (-1) (-5)	NEMA 4X Housing
Tool-06	8 mm & 10 mm Wrench
PS-100	Actuator Power Supply Simulator
S1A, S2A	Auxiliary Switch (es)
P370	Shaft Mount Auxiliary Switch
P...A	Feedback Potentiometers

NOTE: When using AM...24-3... actuators, only use accessories listed on this page.

Typical Specification

Floating point, on/off control damper actuators shall be electronic direct-coupled type, which require no crank arm and linkage and be capable of direct mounting to a shaft up to 1.05" diameter. Actuators shall have brushless DC motor technology and be protected from overload at all angles of rotation. Actuators shall have reversing switch and manual override on the cover. If required, actuators shall be provided with one adjustable SPDT auxiliary switch. Actuators with auxiliary switches must be constructed to meet the requirements for double insulation so an electrical ground is not required to meet agency listings. If required, actuators will be provided with a screw terminal strip for electrical connections (AMX24-3-T). Run time shall be constant and independent of torque. Actuators shall be cULus listed, have a 5-year warranty, and be manufactured under ISO 9001 International Quality Control Standards. Actuators shall be as manufactured by Belimo.

Wiring Diagrams

✂️ INSTALLATION NOTES

- 1 Provide overload protection and disconnect as required.
- 3 Actuators may also be powered by 24 VDC.

For end position indication, interlock control, fan startup, etc., AMB24-3-S incorporates one built-in auxiliary switches: 1 x SPDT, 3A (0.5A) @250 VAC, UL Approved, adjustable 0 to 95.

📄 APPLICATION NOTES

- ◆ Meets cULus or UL and CSA Standard requirements without the need of an electrical ground connection.

⚠️ WARNING Live Electrical Components!

During installation, testing, servicing and troubleshooting of this product, it may be necessary to work with live electrical components. Have a qualified licensed electrician or other individual who has been properly trained in handling live electrical components perform these tasks. Failure to follow all electrical safety precautions when exposed to live electrical components could result in death or serious injury.

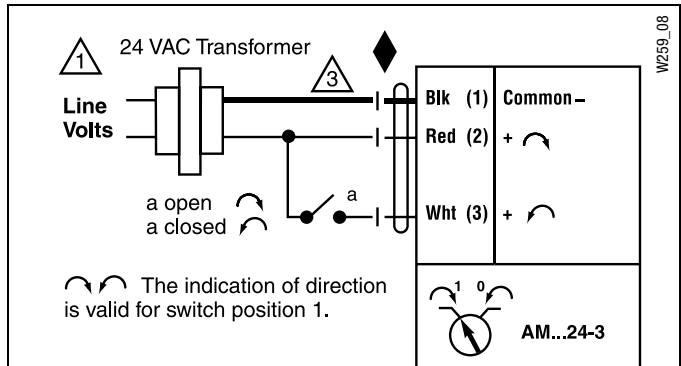

On/Off control

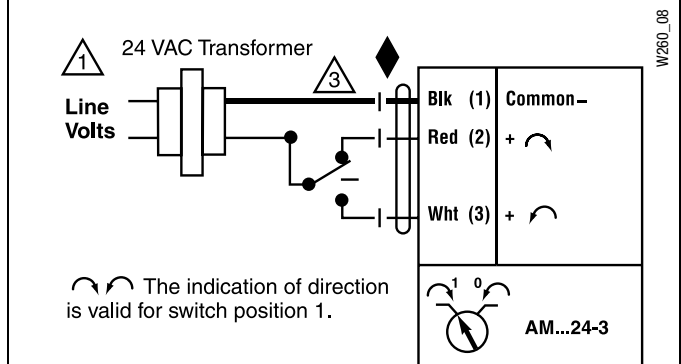

Floating Point or On/Off control

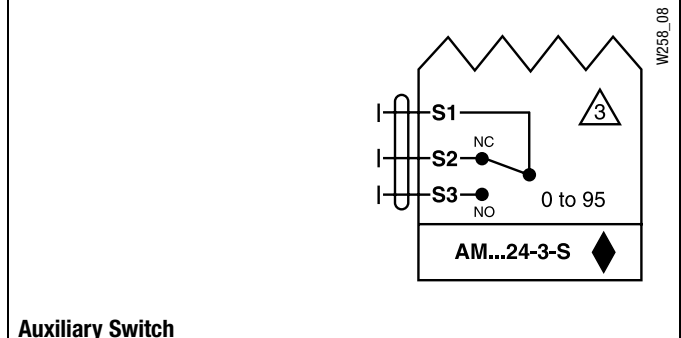

Auxiliary Switch

AMB24-3-T N4, AMB24-3-T N4H

NEMA 4X, On/Off, Floating Point Control, Non-Spring Return, Direct Coupled, 24V



Technical Data	AMB24-3-T N4, AMB24-3-T N4H
Power supply	24 VAC \pm 20% 50/60 Hz 24 VDC \pm 10%
Power consumption	2.5 W (0.5 W) / heater 23 W
Transformer sizing	5.5 VA (Class 2 power source) / heater 20.5 VA
Electrical connection	screw terminal (for 26 to 14 GA wire [heater 15 GA wire]) 1/2" conduit connector
Overload protection	electronic throughout 0 to 95° rotation
Control	on/off, floating point
Input impedance	600 Ω
Angle of rotation	max. 95°, adjust. with mechanical stop
Torque	160 in-lb [16 Nm]
Direction of rotation	reversible with switch
Position indication	pointer
Manual override	external push button
Running time	95 seconds constant independent of load
Humidity	5 to 95% RH non condensing (EN 60730-1)
Ambient temperature	-22°F to 122°F [-30°C to 50°C]
Storage temperature	-40°F to 176°F [-40°C to 80°C]
Housing	UL Type 4X, NEMA 4X, IP66/67
Housing material	UL94-5VA
Agency listings†	ccULus acc. to UL 60730-1A/-2-14, CAN/CSA E60730-1, CSA C22.2 No. 24-93, CE acc. to 89/336/EEC
Noise level	<45dB(A)
Servicing	maintenance free
Quality standard	ISO 9001
Weight	3.3 lbs [1.5 Kg] 3.7 lbs [1.6 Kg] with heater

Torque min. 160 in-lb for control of damper surfaces up to 40 sq ft.

Application

For on/off and floating point control of dampers in HVAC systems. Actuator sizing should be done in accordance with the damper manufacturer's specifications.

The actuator is mounted directly to a damper shaft up to 3/4" in diameter by means of its universal clamp, self-centered default.

Operation

The actuator is not provided with and does not require any limit switches, but is electronically protected against overload. The anti-rotation strap supplied with the actuator will prevent lateral movement.

The AMB24-3-T N4 provides 95° of rotation and a visual indicator indicates position of the actuator. When reaching the damper or actuator end position, the actuator automatically stops. The gears can be manually disengaged with a button on the actuator cover.

The AMB24-3-T N4 actuator uses a sensorless brushless DC motor, which is controlled by an Application Specific Integrated Circuit (ASIC). The ASIC monitors and controls the actuator's rotation and provides a digital rotation sensing (DRS) function to prevent damage to the actuator in a stall condition. Power consumption is reduced in holding mode.

Add-on auxiliary switches or feedback potentiometers are easily fastened directly onto the actuator body for signaling and switching functions.

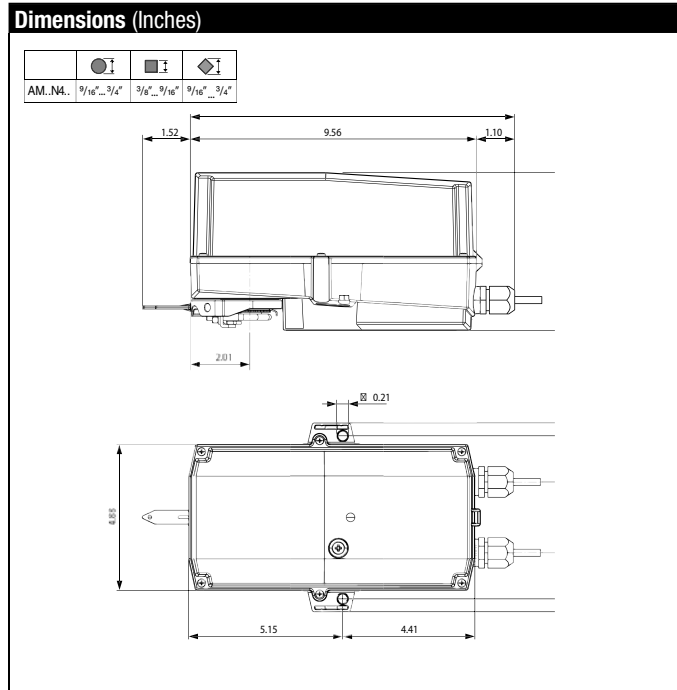

IM40024 - 05/10 - Subject to change. © Belimo Aircontrols (USA), Inc.

Accessories

PS-100	Actuator Power Supply Simulator
S1A, S2A	Auxiliary Switch (es)
P...A	Feedback Potentiometers

NOTE: When using AMB24-3... actuators, only use accessories listed on this page.

Typical Specification

Floating point, on/off control damper actuators shall be electronic direct-coupled type, which require no crank arm and linkage and be capable of direct mounting to a shaft up to 3/4" diameter. Actuators shall have brushless DC motor technology and be protected from overload at all angles of rotation. Actuators shall have reversing switch and manual override on the cover. If required, actuators needing auxiliary switches, can be provided as an add-on accessory. Actuators with auxiliary switches must be constructed to meet the requirements for double insulation so an electrical ground is not required to meet agency listings. Run time shall be constant and independent of torque. Actuators shall be cULus listed, have a 5-year warranty, and be manufactured under ISO 9001 International Quality Control Standards. Actuators shall be as manufactured by Belimo.

Wiring Diagrams

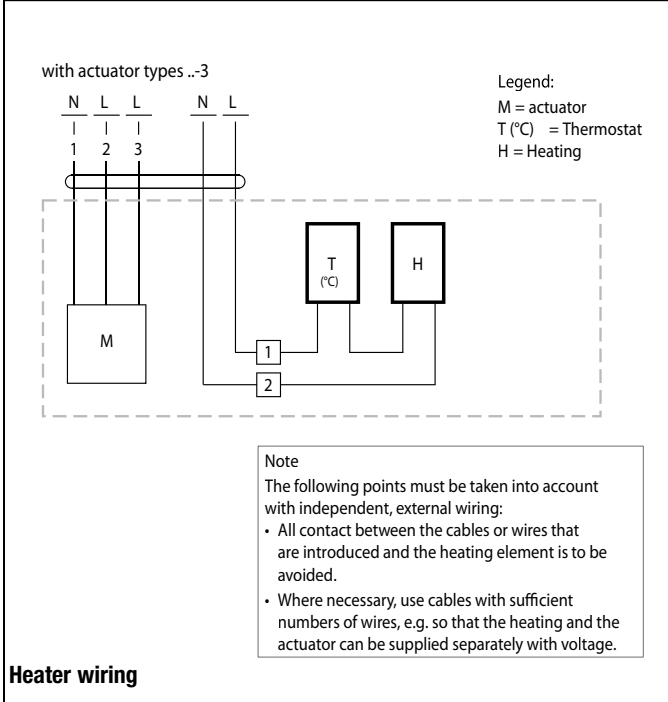

Wiring Diagrams

✂ INSTALLATION NOTES

1 Provide overload protection and disconnect as required.

📄 APPLICATION NOTES

◆ Meets cULus or UL and CSA requirements without the need of an electrical ground connection.

⚠ WARNING Live Electrical Components!

During installation, testing, servicing and troubleshooting of this product, it may be necessary to work with live electrical components. Have a qualified licensed electrician or other individual who has been properly trained in handling live electrical components perform these tasks. Failure to follow all electrical safety precautions when exposed to live electrical components could result in death or serious injury.

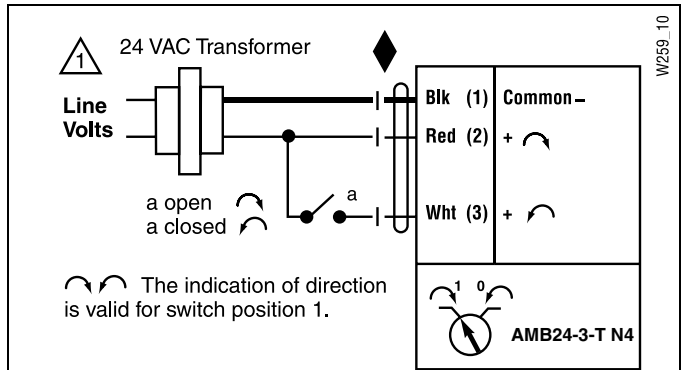

On/Off control

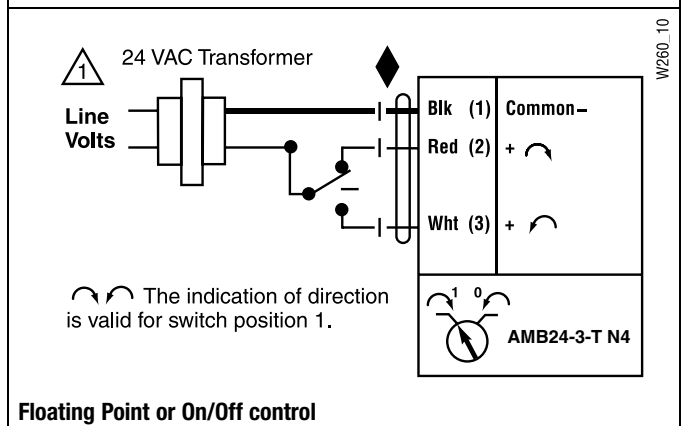

Floating Point or On/Off control

AMX120-3

On/Off, Floating Point, Non-Spring Return, 100 to 240 VAC

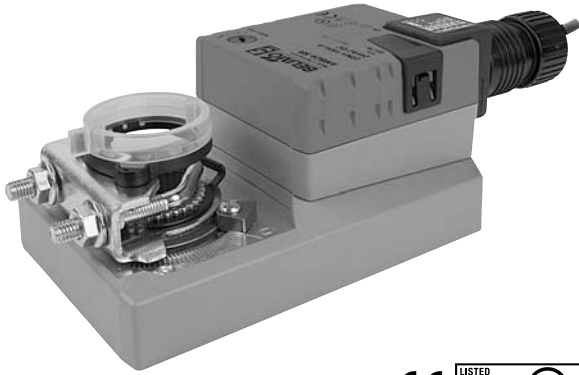

Technical Data	AMX120-3
Power supply	100 to 240 VAC, 50/60 Hz (nominal) 85 to 265 VAC, 50/60 Hz (tolerance)
Power consumption	3 W (0.6 W)
Transformer sizing	7 VA (Class 2 power source)
Electrical connection	18 GA appliance rated cable 1/2" conduit connector protected NEMA 2 (IP54) 3 ft [1m] 10 ft [3m] 16 ft [5m]
Overload protection	electronic throughout 0 to 95° rotation
Control	on/off, floating point
Input impedance	600 Ω
Angle of rotation	max. 95°, adjust. with mechanical stop
Torque	180 in-lb [20 Nm]
Direction of rotation	reversible with switch
Position indication	reflective visual indicator (snap-on)
Manual override	external push button
Running time	300 seconds 150 seconds 95 seconds constant independent of load
Humidity	5 to 95% RH non condensing (EN 60730-1)
Ambient temperature	-22°F to 122°F [-30°C to 50°C]
Storage temperature	-40°F to 176°F [-40°C to 80°C]
Housing	NEMA 2/IP54
Housing material	NEMA 2, IP54, UL enclosure type 2
Agency listings†	cULus acc. to UL 60730-1A/-2-14, CAN/CSA E60730-1:02, CE acc. to 2004/108/EEC and 2006/95/EC
Noise level	<45dB(A)
Servicing	maintenance free
Quality standard	ISO 9001
Weight	2.2 lbs [1.0 Kg]

†Rated Impulse Voltage 4kV, Type of action 1, Control Pollution Degree 3

Torque min. 180 in-lb for control of damper surfaces up to 45 sq ft.

Application

For on/off and floating point control of dampers in HVAC systems. Actuator sizing should be done in accordance with the damper manufacturer's specifications.

The actuator is mounted directly to a damper shaft up to 1.05" in diameter by means of its universal clamp, self-centered default. A crank arm and several mounting brackets are available for applications where the actuator cannot be direct coupled to the damper shaft.

Operation

The actuator is not provided with and does not require any limit switches, but is electronically protected against overload. The anti-rotation strap supplied with the actuator will prevent lateral movement.

The AMX series provides 95° of rotation and a visual indicator indicates position of the actuator. When reaching the damper or actuator end position, the actuator automatically stops. The gears can be manually disengaged with a button on the actuator cover.

The AMX120-3 actuators use a sensorless brushless DC motor, which is controlled by an Application Specific Integrated Circuit (ASIC). The ASIC monitors and controls the actuator's rotation and provides a digital rotation sensing (DRS) function to prevent damage to the actuator in a stall condition. Power consumption is reduced in holding mode.

Add-on auxiliary switches or feedback potentiometers are easily fastened directly onto the actuator body for signaling and switching functions.

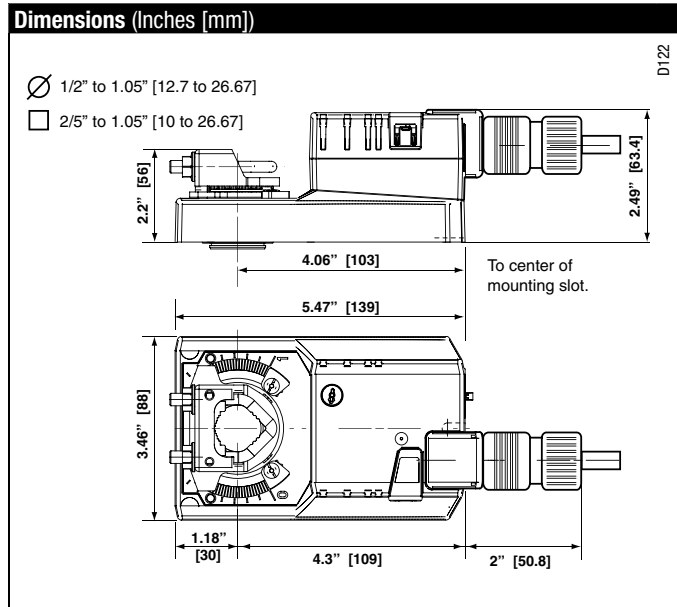

IM40024 - 05/10 - Subject to change. © Belimo Aircontrols (USA), Inc.

Accessories	
K-SA	Reversible Clamp
ZG-100	Universal Mounting Bracket
ZG-101	Universal Mounting Bracket
ZG-103	Universal Mounting Bracket
ZG-104	Universal Mounting Bracket
Z-SMA	AM/SM to AM Retrofit Mounting Bracket
ZG-NMA	Crank arm Adaptor Kit
AV8-25	Universal Shaft Extension
ZG-JSA (-1, 2,3)	Jackshaft Adaptors for Hollow Jackshafts
ZS-100	Weather Shield - Steel
ZS-150	Weather Shield - Polycarbonate
ZS-260	Explosion Proof Housing
ZS-300 (-1) (-5)	NEMA 4X Housing
Tool-06	8 mm & 10 mm Wrench
PS-100	Actuator Power Supply Simulator
S1A, S2A	Auxiliary Switch (es)
P370	Shaft Mount Auxiliary Switch
P...A	Feedback Potentiometers

NOTE: When using AMX120-3 actuators, only use accessories listed on this page.

Typical Specification

Floating point, on/off control damper actuators shall be electronic direct-coupled type, which require no crank arm and linkage and be capable of direct mounting to a shaft up to 1.05" diameter. Actuators shall have brushless DC motor technology and be protected from overload at all angles of rotation. Actuators shall have reversing switch and manual override on the cover. Run time shall be constant and independent of torque. Actuators shall be cULus listed, have a 5-year warranty, and be manufactured under ISO 9001 International Quality Control Standards. Actuators shall be as manufactured by Belimo.

Wiring Diagrams

✂ **INSTALLATION NOTES**

1 Provide overload protection and disconnect as required.

2 **CAUTION Equipment Damage!**
Actuators may be connected in parallel.
Power consumption and input impedance must be observed.

📄 **APPLICATION NOTES**

◆ Meets cULus or UL and CSA Standard requirements without the need of an electrical ground connection.

⚠ **WARNING Live Electrical Components!**
During installation, testing, servicing and troubleshooting of this product, it may be necessary to work with live electrical components. Have a qualified licensed electrician or other individual who has been properly trained in handling live electrical components perform these tasks. Failure to follow all electrical safety precautions when exposed to live electrical components could result in death or serious injury.

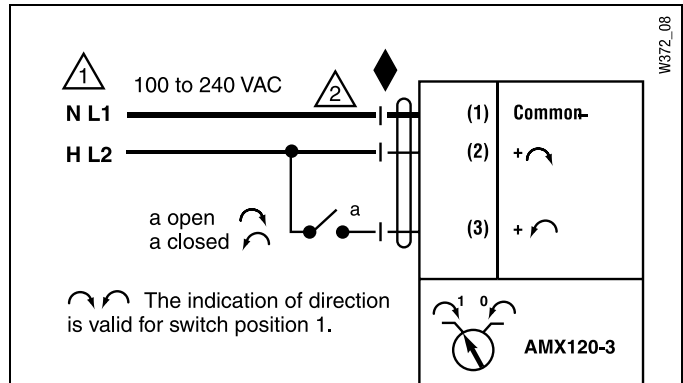

On/Off control

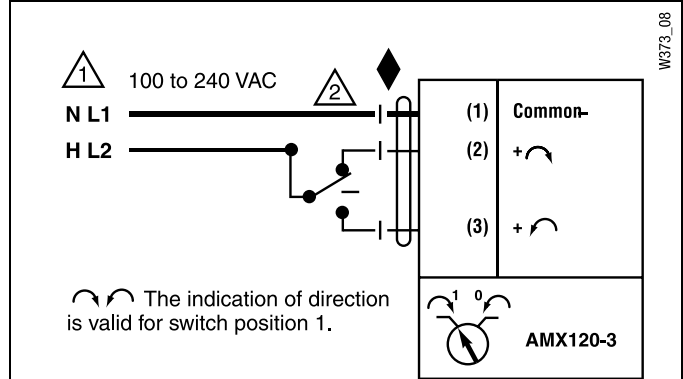

Floating Point or On/Off control

AMB(X)24-SR(-T)

Proportional, Non-Spring Return, 24 V, for 2 to 10 VDC or 4 to 20 mA

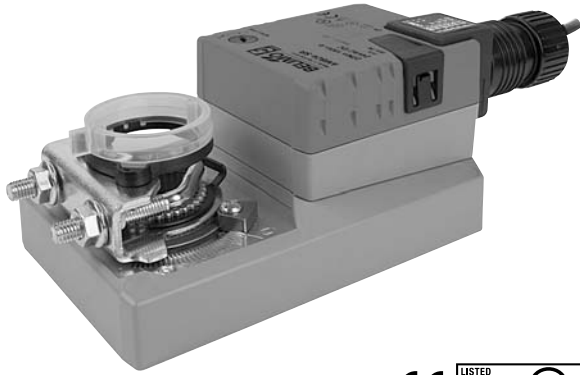

Technical Data	AMB(X)24-SR(-T)
Power supply	24 VAC \pm 20% 50/60 Hz 24 VDC \pm 10%
Power consumption	2.5 W (0.4 W)
Transformer sizing	5 VA (Class 2 power source)
Electrical connection	18 GA plenum rated cable 1/2" conduit connector protected NEMA 2 (IP54) 3 ft [1m] 10 ft [3m] 16 ft [5m]
Overload protection	electronic throughout 0 to 95° rotation
Operating range Y	2 to 10 VDC, 4 to 20 mA
Input impedance	100 k Ω (0.1 mA), 500 Ω
Feedback output U	2 to 10 VDC (max 0.5 mA)
Angle of rotation	max. 95°, adjust. with mechanical stop
Torque	180 in-lb [20 Nm]
Direction of rotation	reversible with switch actuator will move: =CCW with decreasing control signal (10 to 2V) =CW with decreasing control signal (10 to 2V)
Position indication	reflective visual indicator (snap-on)
Manual override	external push button
Running time	300 seconds 150 seconds 95 seconds constant independent of load
Humidity	5 to 95% RH non condensing (EN 60730-1)
Ambient temperature	-22°F to 122°F [-30°C to 50°C]
Storage temperature	-40°F to 176°F [-40°C to 80°C]
Housing	NEMA 2, IP54, UL enclosure type 2
Housing material	UL94-5VA
Agency listings†	cULus acc. to UL 60730-1A/-2-14, CAN/CSA E60730-1:02, CE acc. to 2004/108/EEC and 2006/95/EC
Noise level	<45dB(A)
Servicing	maintenance free
Quality standard	ISO 9001
Weight	2.2 lbs [1000 Kg]

AMB(X)24-SR-T	
Electrical connection	screw terminal (for 26 to 14 GA wire) unprotected (NEMA 1/IP20)

†Rated Impulse Voltage 800V, Type of action 1, Control Pollution Degree 3.

Torque min. 180 in-lb for control of damper surfaces up to 45 sq ft.

Application

For proportional modulation of dampers in HVAC systems. Actuator sizing should be done in accordance with the damper manufacturer's specifications.

The actuator is mounted directly to a damper shaft up to 1.05" in diameter by means of its universal clamp, 1/2" self-centered default. A crank arm and several mounting brackets are available for applications where the actuator cannot be direct coupled to the damper shaft.

The actuator operates in response to a 2 to 10 VDC, or with the addition of a 500 Ω resistor, a 4 to 20 mA control input from an electronic controller or positioner. A 2 to 10 VDC feedback signal is provided for position indication or master-slave applications.

Operation

The actuator is not provided with and does not require any limit switches, but is electronically protected against overload. The anti-rotation strap supplied with the actuator will prevent lateral movement.

The AMB(X) series provides 95° of rotation and a visual indicator indicates position of the actuator. When reaching the damper or actuator end position, the actuator automatically stops. The gears can be manually disengaged with a button on the actuator cover.

The AMB(X)24-SR... actuators use a sensorless brushless DC motor, which is controlled by an Application Specific Integrated Circuit (ASIC). The ASIC monitors and controls the actuator's rotation and provides a digital rotation sensing (DRS) function to prevent damage to the actuator in a stall condition. Power consumption is reduced in holding mode.

Add-on auxiliary switches or feedback potentiometers are easily fastened directly onto the actuator body for signaling and switching functions.

Dimensions (Inches [mm])

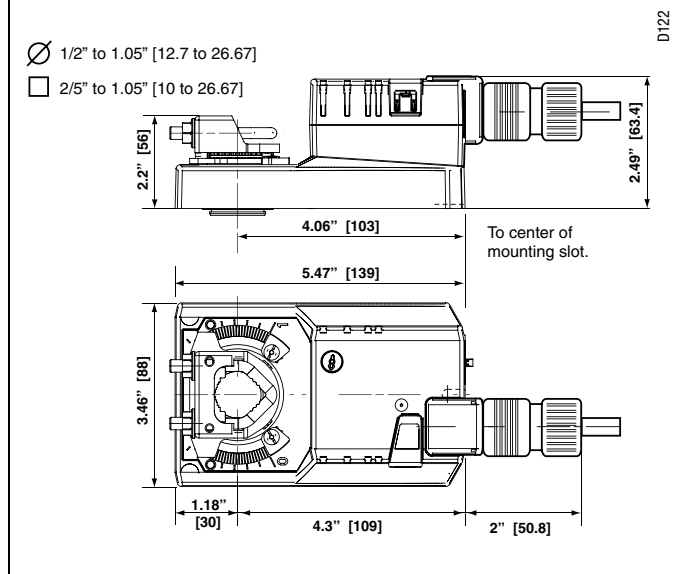

IM40024 - 05/10 - Subject to change. © Belimo Aircontrols (USA), Inc.

Accessories	
K-SA	Reversible Clamp
ZG-100	Universal Mounting Bracket
ZG-101	Universal Mounting Bracket
ZG-103	Universal Mounting Bracket
ZG-104	Universal Mounting Bracket
Z-SMA	AM/SM to AM Retrofit Mounting Bracket
ZG-NMA	Crank arm Adaptor Kit
AV8-25	Universal Shaft Extension
ZG-JSA (-1, 2, 3)	Jackshaft Adaptors for Hollow Jackshafts
ZS-T	Terminal Cover NEMA 2
ZS-100	Weather Shield - Steel
ZS-150	Weather Shield - Polycarbonate
ZS-260	Explosion Proof Housing
ZS-300 (-1) (-5)	NEMA 4X Housing
Tool-06	8 mm & 10 mm Wrench
S1A, S2A	Auxiliary Switch (es)
P370	Shaft Mount Auxiliary Switch
P...A	Feedback Potentiometers
SGA24	Min positioners in NEMA 4 housing
SGF24	Min positioners for flush panel mounting
PTA-250	Pulse Width Modulation Interface
IRM-100	Input Rescaling Module
ADS-100	Analog to Digital Switch
ZG-R01	Resistor for 4 to 20 mA Conversion
NSV24 US	Battery Back-Up Module
ZG-X40	Transformer

NOTE: When using AMB(X)24-SR... actuators, only use accessories listed on this page.

Typical Specification

Proportional control damper actuators shall be electronic direct-coupled type, which require no crank arm and linkage and be capable of direct mounting to a shaft up to 1.05" diameter. Actuators must provide proportional damper control in response to a 2 to 10 VDC or, with the addition of a 500 Ω resistor, a 4 to 20 mA control input from an electronic controller or positioner. Actuators shall have brushless DC motor technology and be protected from overload at all angles of rotation. Actuators shall have reversing switch and manual override on the cover. If required, actuator will be provided with screw terminal strip for electrical connections (AMX24-SR-T). Run time shall be constant and independent of torque. A 2 to 10 VDC feedback signal shall be provided for position indication. Actuators shall be cULus listed, have a 5-year warranty, and be manufactured under ISO 9001 International Quality Control Standards. Actuators shall be as manufactured by Belimo.

Wiring Diagrams

✂️ INSTALLATION NOTES

- 1 Provide overload protection and disconnect as required.
- 2 **CAUTION Equipment Damage!**
Actuators may be connected in parallel.
Power consumption and input impedance must be observed.
- 3 Actuators may also be powered by 24 VDC.
- 5 Only connect common to neg. (-) leg of control circuits.

📄 APPLICATION NOTES

- ◆ The ZG-R01 500 Ω resistor converts the 4 to 20 mA control signal to 2 to 10 VDC, up to 2 actuators may be connected in parallel.

⚠️ WARNING Live Electrical Components!

During installation, testing, servicing and troubleshooting of this product, it may be necessary to work with live electrical components. Have a qualified licensed electrician or other individual who has been properly trained in handling live electrical components perform these tasks. Failure to follow all electrical safety precautions when exposed to live electrical components could result in death or serious injury.

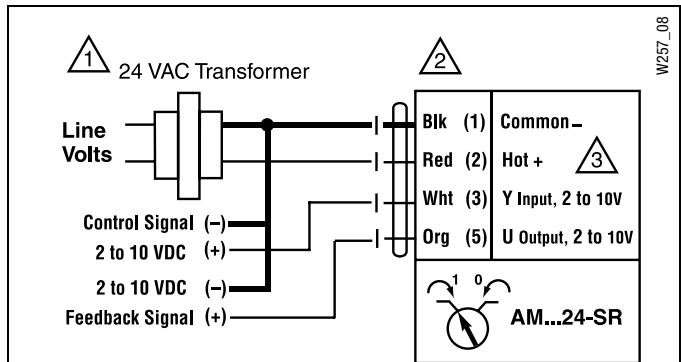

2 to 10 VDC control

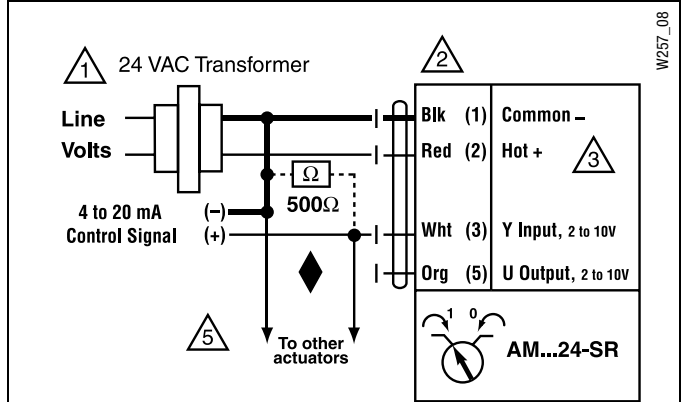

4 to 20 mA control

AMB24-SR-T N4, AMB24-SR-T N4H

NEMA 4X, Proportional Control, Non-Spring Return, Direct Coupled, 24V, for 2 to 10 VDC and 4 to 20 mA



Technical Data	AMB24-SR-T N4, AMB24-SR-T N4H
Power supply	24 VAC \pm 20% 50/60 Hz 24 VDC \pm 10%
Power consumption	2.5 W (0.4 W) / heater 23 W
Transformer sizing	5 VA (Class 2 power source) / heater 20 VA
Electrical connection	screw terminal (for 26 to 14 GA wire [heater 15 GA wire]) 1/2" conduit connector
Overload protection	electronic throughout 0 to 95° rotation
Operating range Y	2 to 10 VDC, 4 to 20 mA
Input impedance	100 k Ω (0.1 mA), 500 Ω
Feedback output U	2 to 10 VDC (max 0.5 mA)
Angle of rotation	max. 95°, adjust. with mechanical stop
Torque	160 in-lb [16 Nm]
Direction of rotation	reversible with switch
Position indication	pointer
Manual override	external push button
Running time	95 seconds, constant independent of load
Humidity	5 to 95% RH non condensing (EN 60730-1)
Ambient temperature	-22°F to 122°F [-30°C to 50°C]
Storage temperature	-40°F to 176°F [-40°C to 80°C]
Housing	UL type 4X, NEMA 4X, IP66/67
Housing material	UL94-5VA
Agency listings†	cULus acc. to UL 60730-1A/-2-14, CAN/CSA E60730-1, CSA C22.2 No. 24-93, CE acc. to 89/336/EEC
Noise level	<45dB(A)
Servicing	maintenance free
Quality standard	ISO 9001
Weight	3.3 lbs [1.5 Kg] 3.7 lbs [1.6 Kg] with heater

†Rated Impulse Voltage 800V, Type of action 1, Control Pollution Degree 3.

Torque min. 160 in-lb for control of damper surfaces up to 40 sq ft.

Application

For proportional modulation of dampers in HVAC systems. Actuator sizing should be done in accordance with the damper manufacturer's specifications.

The actuator is mounted directly to a damper shaft up to 3/4" in diameter by means of its universal clamp.

The actuator operates in response to a 2 to 10 VDC, or with the addition of a 500 Ω resistor, a 4 to 20 mA control input from an electronic controller or positioner. A 2 to 10 VDC feedback signal is provided for position indication or master-slave applications.

Operation

The actuator is not provided with and does not require any limit switches, but is electronically protected against overload. The anti-rotation strap supplied with the actuator will prevent lateral movement.

The AMB24-SR-T N4 provides 95° of rotation and a visual indicator indicates position of the actuator. When reaching the damper or actuator end position, the actuator automatically stops. The gears can be manually disengaged with a button on the actuator cover.

The AMB24-SR-T N4 actuator uses a sensorless brushless DC motor, which is controlled by an Application Specific Integrated Circuit (ASIC). The ASIC monitors and controls the actuator's rotation and provides a digital rotation sensing (DRS) function to prevent damage to the actuator in a stall condition. Power consumption is reduced in holding mode.

Add-on auxiliary switches or feedback potentiometers are easily fastened directly onto the actuator body for signaling and switching functions.

Dimensions (Inches [mm])

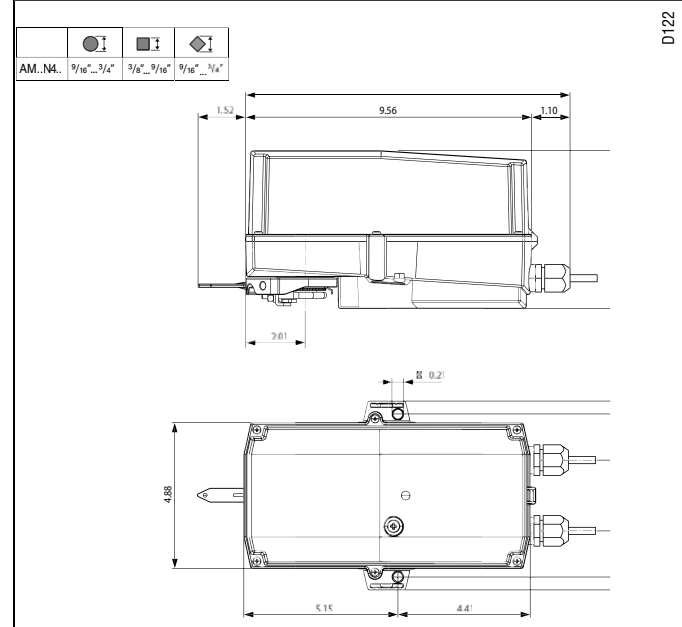

IM40024 - 05/10 - Subject to change. © Belimo Aircontrols (USA), Inc.

Accessories	
S1A, S2A	Auxiliary Switch (es)
P...A	Feedback Potentiometers
SGA24	Min positioners for surface mounting
SGF24	Min positioners for flush panel mounting
PTA-250	Pulse Width Modulation Interface
IRM-100	Input Rescaling Module
ADS-100	Analog to Digital Switch
ZG-R01	Resistor for 4 to 20 mA Conversion
NSV24 US	Battery Back-Up Module
ZG-X40	Transformer

Typical Specification

Proportional control damper actuators shall be electronic direct-coupled type, which require no crank arm and linkage and be capable of direct mounting to a shaft up to 3/4" diameter. Actuators must provide proportional damper control in response to a 2 to 10 VDC or, with the addition of a 500 Ω resistor, a 4 to 20 mA control input from an electronic controller or positioner. Actuators shall have brushless DC motor technology and be protected from overload at all angles of rotation. Actuators shall have reversing switch and manual override on the cover. Run time shall be constant and independent of torque. A 2 to 10 VDC feedback signal shall be provided for position indication. Actuators shall be cULus listed, have a 5-year warranty, and be manufactured under ISO 9001 International Quality Control Standards. Actuators shall be as manufactured by Belimo.

Wiring Diagram

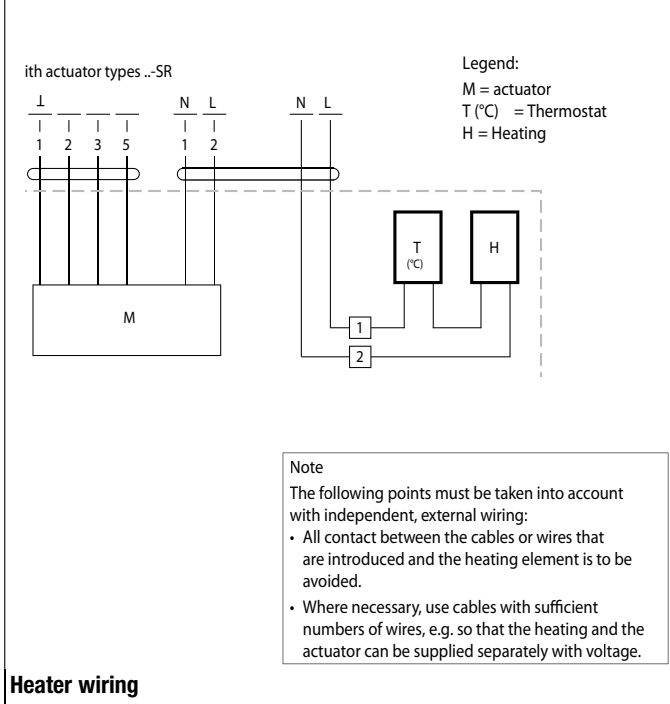

M40024 - 05/10 - Subject to change. © Belimo Aircontrols (USA), Inc.

Wiring Diagram

INSTALLATION NOTES

- 1 Provide overload protection and disconnect as required.
- 2 **CAUTION Equipment damage!**
Actuators may be connected in parallel. Power consumption and input impedance must be observed.
- 3 Actuators may also be powered by 24 VDC.
- 5 Only connect common to neg. (-) leg of control circuits.

APPLICATION NOTES

The ZG-R01 500 Ω resistor converts the 4 to 20 mA control signal to 2 to 10 VDC, up to 2 actuators may be connected in parallel.

WARNING Live Electrical Components!

During installation, testing, servicing and troubleshooting of this product, it may be necessary to work with live electrical components. Have a qualified licensed electrician or other individual who has been properly trained in handling live electrical components perform these tasks. Failure to follow all electrical safety precautions when exposed to live electrical components could result in death or serious injury.

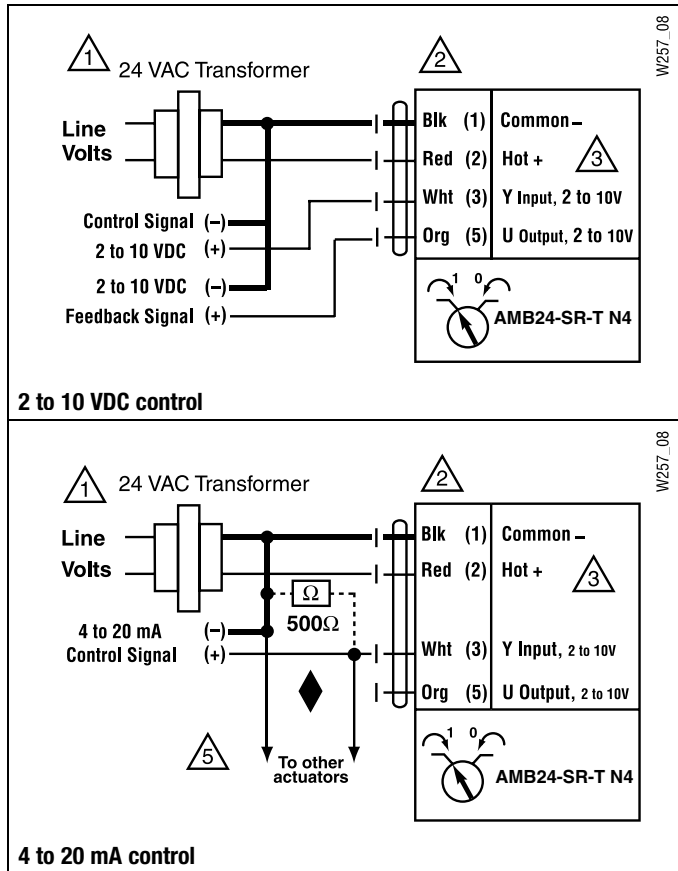

AMX120-SR

Proportional, Non-Spring Return, 100 to 240 VAC, for 2 to 10 VDC or 4 to 20 mA



Technical Data	AMX120-SR
Power supply	100 to 240 VAC, 50/60 Hz (nominal) 85 to 265 VAC, 50/60 Hz (tolerance)
Power consumption	4 W (1 W)
Transformer sizing	7.5 VA (Class 2 power source)
Electrical connection	18 GA appliance rated cable 1/2" conduit connector protected NEMA 2 (IP54) 3 ft [1m] 10 ft [3m] 16 ft [5m]
Overload protection	electronic throughout 0 to 95° rotation
Operating range Y	2 to 10 VDC, 4 to 20 mA
Input impedance	100 kΩ (0.1 mA), 500 Ω
Feedback output U	2 to 10 VDC (max 0.5 mA)
Angle of rotation	max. 95°, adjust. with mechanical stop
Torque	180 in-lb [20 Nm]
Direction of rotation	reversible with / switch actuator will move: =CCW with decreasing control signal (10 to 2V) =CW with decreasing control signal (10 to 2V)
Position indication	reflective visual indicator (snap-on)
Manual override	external push button
Running time	300 seconds 150 seconds 95 seconds constant independent of load
Humidity	5 to 95% RH non condensing (EN 60730-1)
Ambient temperature	-22°F to 122°F [-30°C to 50°C]
Storage temperature	-40°F to 176°F [-40°C to 80°C]
Housing	NEMA 2, IP54, UL enclosure type 2
Housing material	UL94-5VA
Agency listings†	cULus acc. to UL 60730-1A/-2-14, CAN/CSA E60730-1:02, CE acc. to 2004/108/EEC and 2006/95/EC
Noise level	<45dB(A)
Servicing	maintenance free
Quality standard	ISO 9001
Weight	2.2 lbs [1.0 Kg]

†Rated Impulse Voltage 4kV, Type of action 1, Control Pollution Degree 3.

Torque min. 180 in-lb for control of damper surfaces up to 45 sq ft.

Application

For proportional modulation of dampers in HVAC systems. Actuator sizing should be done in accordance with the damper manufacturer's specifications.

The actuator is mounted directly to a damper shaft up to 1.05" in diameter by means of its universal clamp, 1/2" self-centered default. A crank arm and several mounting brackets are available for applications where the actuator cannot be direct coupled to the damper shaft.

The actuator operates in response to a 2 to 10 VDC, or with the addition of a 500 Ω resistor, a 4 to 20 mA control input from an electronic controller or positioner. A 2 to 10 VDC feedback signal is provided for position indication or master-slave applications.

Operation

The actuator is not provided with and does not require any limit switches, but is electronically protected against overload. The anti-rotation strap supplied with the actuator will prevent lateral movement.

The AMX series provides 95° of rotation and a visual indicator indicates position of the actuator. When reaching the damper or actuator end position, the actuator automatically stops. The gears can be manually disengaged with a button on the actuator cover.

The AMX120-SR actuators use a sensorless brushless DC motor, which is controlled by an Application Specific Integrated Circuit (ASIC). The ASIC monitors and controls the actuator's rotation and provides a digital rotation sensing (DRS) function to prevent damage to the actuator in a stall condition. Power consumption is reduced in holding mode.

Add-on auxiliary switches or feedback potentiometers are easily fastened directly onto the actuator body for signaling and switching functions.

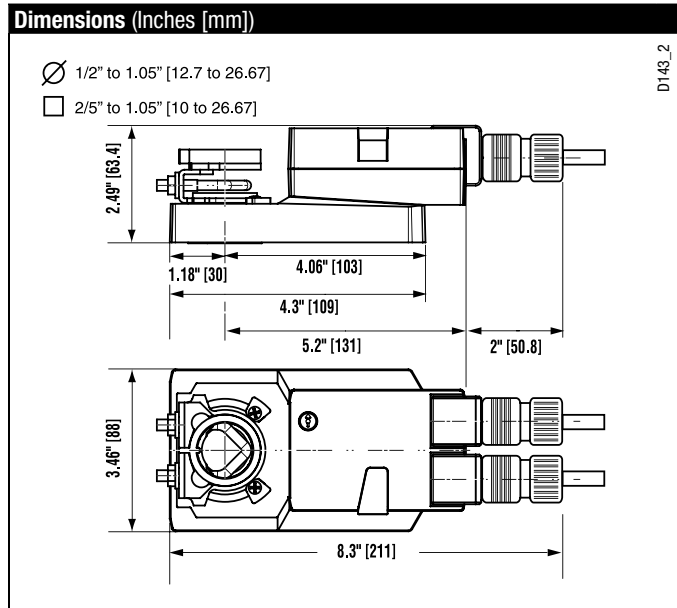

M40024 - 05/10 - Subject to change. © Belimo Aircontrols (USA), Inc.

Accessories	
K-SA	Reversible Clamp
ZG-100	Universal Mounting Bracket
ZG-101	Universal Mounting Bracket
ZG-103	Universal Mounting Bracket
ZG-104	Universal Mounting Bracket
Z-SMA	AM/SM to AM Retrofit Mounting Bracket
ZG-NMA	Crank arm Adaptor Kit
AV8-25	Universal Shaft Extension
ZG-JSA (-1, 2, 3)	Jackshaft Adaptors for Hollow Jackshafts
ZS-100	Weather Shield - Steel
ZS-150	Weather Shield - Polycarbonate
ZS-260	Explosion Proof Housing
ZS-300 (-1) (-5)	NEMA 4X Housing
Tool-06	8 mm & 10 mm Wrench
S1A, S2A	Auxiliary Switch (es)
P370	Shaft Mount Auxiliary Switch
P...A	Feedback Potentiometers
SGA24	Min positioners in NEMA 4 housing
SGF24	Min positioners for flush panel mounting
PTA-250	Pulse Width Modulation Interface
IRM-100	Input Rescaling Module
ADS-100	Analog to Digital Switch
ZG-R01	Resistor for 4 to 20 mA Conversion
NSV24 US	Battery Back-Up Module
ZG-X40	Transformer

NOTE: When using AMX120-SR actuators, only use accessories listed on this page.

Typical Specification

Proportional control damper actuators shall be electronic direct-coupled type, which require no crank arm and linkage and be capable of direct mounting to a shaft up to 1.05" diameter. Actuators must provide proportional damper control in response to a 2 to 10 VDC or, with the addition of a 500 Ω resistor, a 4 to 20 mA control input from an electronic controller or positioner. Actuators shall have brushless DC motor technology and be protected from overload at all angles of rotation. Actuators shall have reversing switch and manual override on the cover. Run time shall be constant and independent of torque. A 2 to 10 VDC feedback signal shall be provided for position indication. Actuators shall be cULus listed, have a 5-year warranty, and be manufactured under ISO 9001 International Quality Control Standards. Actuators shall be as manufactured by Belimo.

Wiring Diagram

INSTALLATION NOTES

- 1 Provide overload protection and disconnect as required.
- 2 **CAUTION Equipment Damage!**
Actuators may be connected in parallel. Power consumption and input impedance must be observed.
- 5 Only connect common to neg. (-) leg of control circuits.

APPLICATION NOTES

- ◆ Meets cULus or UL and CSA Standard requirements without the need of an electrical ground connection.
- ◆ The ZG-R01 500 Ω resistor converts the 4 to 20 mA control signal to 2 to 10 VDC, up to 2 actuators may be connected in parallel.

WARNING Live Electrical Components!

During installation, testing, servicing and troubleshooting of this product, it may be necessary to work with live electrical components. Have a qualified licensed electrician or other individual who has been properly trained in handling live electrical components perform these tasks. Failure to follow all electrical safety precautions when exposed to live electrical components could result in death or serious injury.

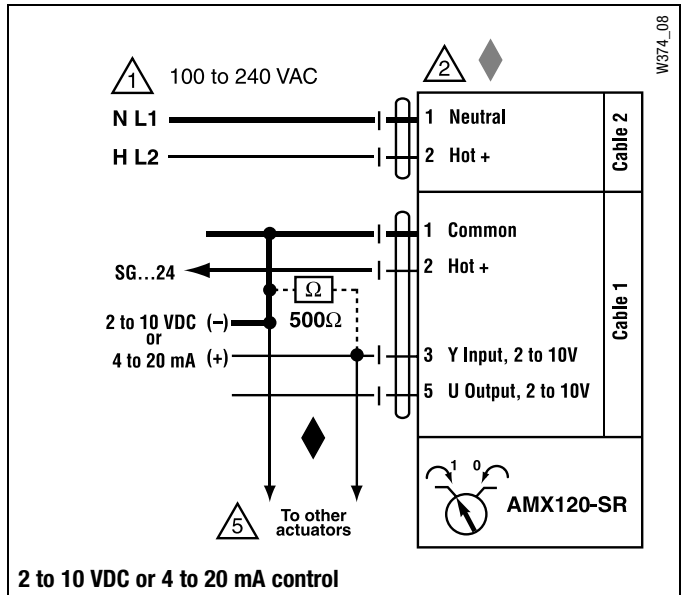

AMB(X)24-MFT

Proportional, Non-Spring Return, 24 V, Multi-Function Technology®



MFT



Technical Data	AMB(X)24-MFT
Power supply	24 VAC ± 20% 50/60 Hz 24 VDC ± 10%
Power consumption	3.5 W (1.3 W)
Transformer sizing	6 VA (Class 2 power source)
Electrical connection	18 GA plenum rated cable 1/2" conduit connector protected NEMA 2 (IP54) 3 ft [1m] 10 ft [3m] 16 ft [5m]
Overload protection	electronic throughout 0 to 95° rotation
Operating range Y	2 to 10 VDC, 4 to 20 mA (default) variable (VDC, PWM, floating point, on/off)
Input impedance	100 kΩ (0.1 mA), 500 Ω 1500 W (PWM, floating point, on/off)
Feedback output U	2 to 10 VDC, 0.5 mA max VDC variable
Angle of rotation	max. 95°, adjustable with mechanical stop electronically variable
Torque	180 in-lb [20 Nm]
Direction of rotation	reversible with switch
Position indication	reflective visual indicator (snap-on)
Manual override	external push button
Running time	150 seconds (default) variable (90 to 350 seconds)
Humidity	5 to 95% RH non condensing (EN 60730-1)
Ambient temperature	-22°F to 122°F [-30°C to 50°C]
Storage temperature	-40°F to 176°F [-40°C to 80°C]
Housing	NEMA 2, IP54, UL enclosure type 2
Housing material	UL94-5VA
Agency listings†	cULus acc. to UL 60730-1A/-2-14, CAN/CSA E60730-1:02, CE acc. to 2004/108/EEC and 2006/95/EC
Noise level	<45dB(A)
Servicing	maintenance free
Quality standard	ISO 9001
Weight	2.6 lbs [1.2 kg]

†Rated Impulse Voltage 800V, Type of action 1, Control Pollution Degree 3.

Torque min. 180 in-lb for control of damper surfaces up to 45 sq ft.

Application

For proportional modulation of dampers in HVAC systems. Actuator sizing should be done in accordance with the damper manufacturer's specifications.

The actuator is mounted directly to a damper shaft up to 1.05" in diameter by means of its universal clamp, 1/2" self-centered default. A crank arm and several mounting brackets are available for applications where the actuator cannot be direct coupled to the damper shaft.

The default parameters for 2 to 10 VDC applications of the ...MFT actuator are assigned during manufacturing. If necessary, custom versions of the actuators can be ordered. The parameters can be changed by two means: pre-set and custom configurations from Belimo or on-site configurations using the Belimo PC-Tool software.

Operation

The actuator is not provided with and does not require any limit switches, but is electronically protected against overload. The anti-rotation strap supplied with the actuator will prevent lateral movement.

The AMB(X) series provides 95° of rotation and a visual indicator indicates position of the actuator. When reaching the damper or actuator end position, the actuator automatically stops. The gears can be manually disengaged with a button on the actuator cover.

The AMB(X)24-MFT actuators use a brushless DC motor, which is controlled by an Application Specific Integrated Circuit (ASIC). The ASIC monitors and controls the actuator's rotation and provides a digital rotation sensing (DRS) function to prevent damage to the actuator in a stall condition. Power consumption is reduced in holding mode.

Add-on auxiliary switches or feedback potentiometers are easily fastened directly onto the actuator body for signaling and switching functions.

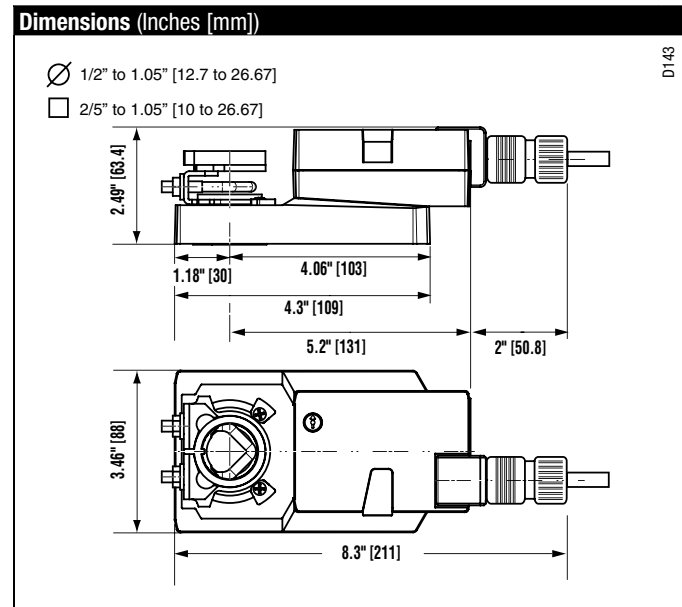

M40024 - 05/10 - Subject to change. © Belimo Aircontrols (USA), Inc.

Accessories

K-SA	Reversible Clamp
ZG-100	Universal Mounting Bracket
ZG-101	Universal Mounting Bracket
ZG-103	Universal Mounting Bracket
ZG-104	Universal Mounting Bracket
Z-SMA	AM/SM to AM Retrofit Mounting Bracket
ZG-AMA	Crank arm Adaptor Kit
AV8-25	Universal Shaft Extension
ZG-JSA (-1, 2, 3)	Jackshaft Adaptors for Hollow Jackshafts
ZS-100	Weather Shield - Steel
ZS-150	Weather Shield - Polycarbonate
ZS-260	Explosion Proof Housing
ZS-300 (-1) (-5)	NEMA 4X Housing
Tool-06	8 mm & 10 mm Wrench
S1A, S2A	Auxiliary Switch (es)
P370	Shaft Mount Auxiliary Switch
P...A	Feedback Potentiometers
SGA24	Min positioners in NEMA 4 housing
SGF24	Min positioners for flush panel mounting
ADS-100	Analog to Digital Switch
ZG-R01	Resistor for 4 to 20 mA Conversion
NSV24 US	Battery Back-Up Module
ZG-X40	Transformer

NOTE: When using AMB(X)24-MFT... actuators, only use accessories listed on this page.

Typical Specification

Proportional control damper actuators shall be electronic direct-coupled type, which require no crank arm and linkage and be capable of direct mounting to a shaft up to 1.05" diameter. Actuators must provide proportional damper control in response to a 2 to 10 VDC or, with the addition of a 500 Ω resistor, a 4 to 20 mA control input from an electronic controller or positioner. Actuators shall have brushless DC motor technology and be protected from overload at all angles of rotation. Actuators shall have reversing switch and manual override on the cover. Run time shall be constant and independent of torque. Actuators shall be cULus listed, have a 5-year warranty, and be manufactured under ISO 9001 International Quality Control Standards. Actuators shall be as manufactured by Belimo.

Wiring Diagrams

INSTALLATION NOTES

- 1 Provide overload protection and disconnect as required.
- 2 **CAUTION Equipment Damage!**
Actuators may be connected in parallel if not mechanically mounted to the same shaft. Power consumption and input impedance must be observed.
- 3 Actuators may also be powered by 24 VDC.
- 4 Position feedback cannot be used with Triac sink controller. The actuator internal common reference is not compatible.
- 5 Control signal may be pulsed from either the Hot (source) or the Common (sink) 24 VAC line.
- 8 Contact closures A & B also can be triacs.
- 9 For triac sink the common connection from the actuator must be connected to the hot connection of the controller.

APPLICATION NOTES

- ◆ The ZG-R01 500 Ω resistor may be used.

WARNING Live Electrical Components!

During installation, testing, servicing and troubleshooting of this product, it may be necessary to work with live electrical components. Have a qualified licensed electrician or other individual who has been properly trained in handling live electrical components perform these tasks. Failure to follow all electrical safety precautions when exposed to live electrical components could result in death or serious injury.

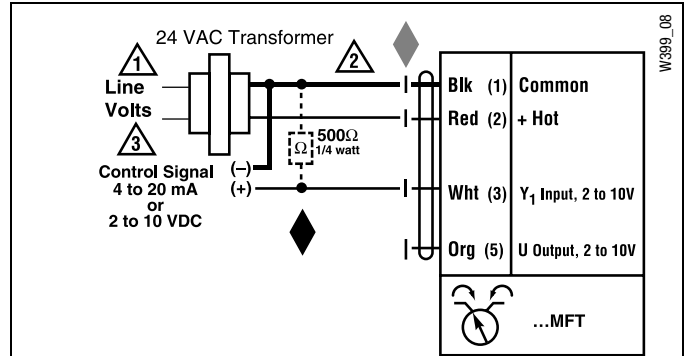

VDC/4-20 mA

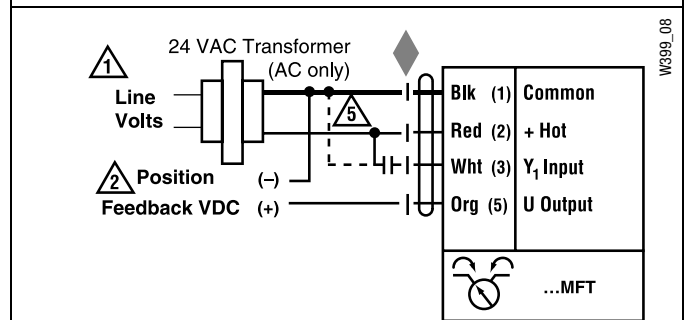

PWM

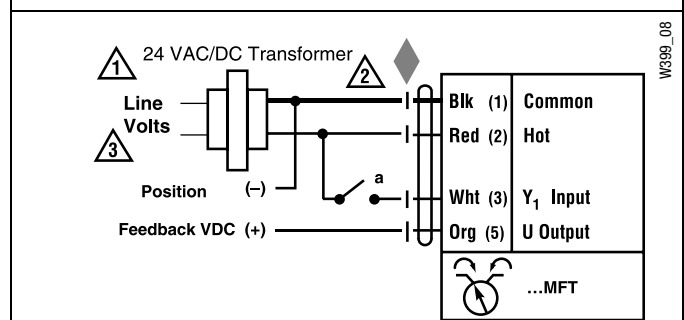

On/Off control

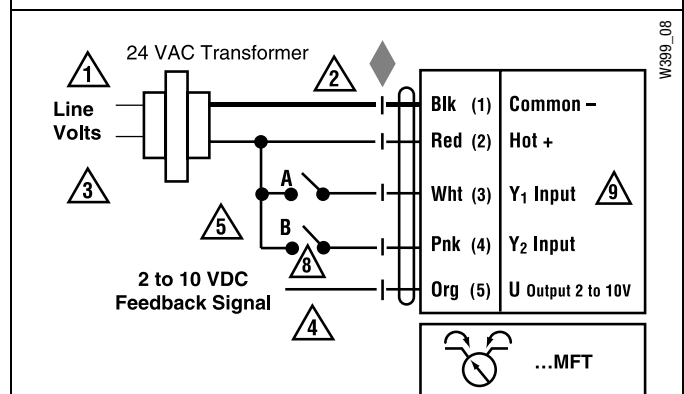

Floating Point control

AMX24-MFT-T N4, AMX24-MFT-T N4H

NEMA 4X, Proportional Control, Non-Spring Return, Direct Coupled, 24V, Multi-Function Technology®



MFT



Technical Data	AMX24-MFT-T N4, AMX24-MFT-T N4H
Power supply	24 VAC ± 20% 50/60 Hz 24 VDC ± 10%
Power consumption	3.5 W (1.25 W) / heater 24 W
Transformer sizing	6 VA (Class 2 power source) / heater 21 VA
Electrical connection	screw terminal (for 26 to 14 GA wire [heater 15 GA wire]) 1/2" conduit connector
Overload protection	electronic throughout 0 to 95° rotation
Operating range Y	2 to 10 VDC, 4 to 20 mA (default) variable (VDC, PWM, floating point, on/off)
Input impedance	100 kΩ (0.1 mA), 500 Ω 1500 Ω (PWM, floating point, on/off)
Feedback output U	2 to 10 VDC, 0.5 mA max VDC variable
Angle of rotation	max. 95°, adjustable with mechanical stop electronically variable
Torque	160 in-lb [16 Nm]
Direction of rotation	reversible with switch
Position indication	pointer
Manual override	external push button
Running time	150 seconds (default) variable (90 to 300 seconds)
Humidity	5 to 95% RH non condensing (EN 60730-1)
Ambient temperature	-22°F to 122°F [-30°C to 50°C]
Storage temperature	-40°F to 176°F [-40°C to 80°C]
Housing	UL type 4X, NEMA 4X, IP66/67
Housing material	UL94-5VA
Agency listings†	cULus acc. to UL 60730-1A/-2-14, CAN/CSA E60730-1, CSA C22.2 No. 24-93, CE acc. to 89/336/EEC
Noise level	<45dB(A)
Servicing	maintenance free
Quality standard	ISO 9001
Weight	3.7 lbs [1.6 kg] 4.1 lbs [1.8 kg] with heater

†Rated Impulse Voltage 800V, Type of action 1, Control Pollution Degree 3.

Torque min. 160 in-lb for control of damper surfaces up to 40 sq ft.

Application

For proportional modulation of dampers in HVAC systems. Actuator sizing should be done in accordance with the damper manufacturer's specifications.

The actuator is mounted directly to a damper shaft up to 3/4" in diameter by means of its universal clamp.

The default parameters for 2 to 10 VDC applications of the ...MFT actuator are assigned during manufacturing. If necessary, custom versions of the actuators can be ordered. The parameters can be changed by two means: pre-set and custom configurations from Belimo or on-site configurations using the Belimo PC-Tool software.

Operation

The actuator is not provided with and does not require any limit switches, but is electronically protected against overload. The anti-rotation strap supplied with the actuator will prevent lateral movement.

The AMX24-MFT-T N4 provides 95° of rotation and a visual indicator indicates position of the actuator. When reaching the damper or actuator end position, the actuator automatically stops. The gears can be manually disengaged with a button on the actuator cover.

The AMX24-MFT-T N4 actuator uses a brushless DC motor, which is controlled by an Application Specific Integrated Circuit (ASIC). The ASIC monitors and controls the actuator's rotation and provides a digital rotation sensing (DRS) function to prevent damage to the actuator in a stall condition. Power consumption is reduced in holding mode.

Add-on auxiliary switches or feedback potentiometers are easily fastened directly onto the actuator body for signaling and switching functions.

Dimensions (Inches)

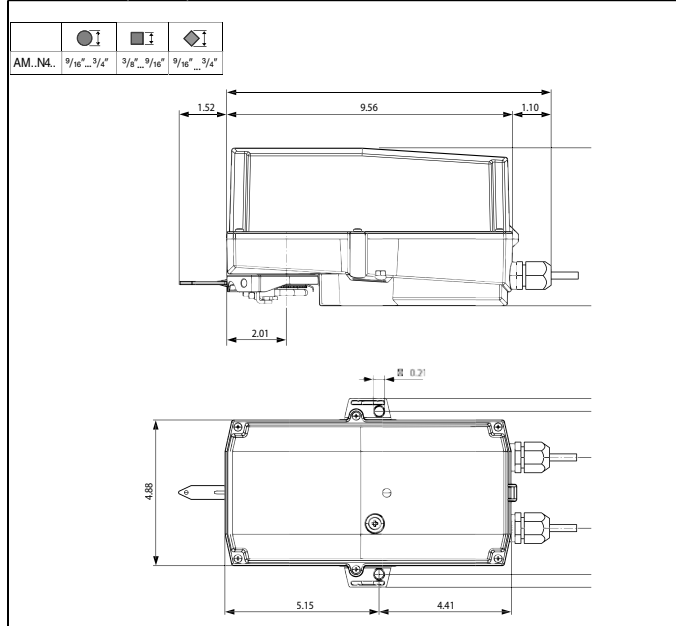

IM40024 - 05/10 - Subject to change. © Belimo Aircontrols (USA), Inc.

Accessories

ZS-100	Weather Shield - Steel
S1A, S2A	Auxiliary Switch (es)
P...A	Feedback Potentiometers
SGA24	Min positioners for surface mounting
SGF24	Min positioners for flush panel mounting
ADS-100	Analog to Digital Switch
ZG-R01	Resistor for 4 to 20 mA Conversion
NSV24 US	Battery Back-Up Module
ZG-X40	Transformer

Typical Specification

Proportional control damper actuators shall be electronic direct-coupled type, which require no crank arm and linkage and be capable of direct mounting to a shaft up to 3/4" diameter. Actuators must provide proportional damper control in response to a 2 to 10 VDC or, with the addition of a 500 Ω resistor, a 4 to 20 mA control input from an electronic controller or positioner. Actuators shall have brushless DC motor technology and be protected from overload at all angles of rotation. Actuators shall have reversing switch and manual override on the cover. Run time shall be constant and independent of torque. Actuators shall be cULus listed, have a 5-year warranty, and be manufactured under ISO 9001 International Quality Control Standards. Actuators shall be as manufactured by Belimo.

Wiring Diagrams

INSTALLATION NOTES

- 1 Provide overload protection and disconnect as required.
- 2 **CAUTION Equipment damage!** Actuators may be connected in parallel if not mechanically mounted to the same shaft. Power consumption and input impedance must be observed.
- 3 Actuators may also be powered by 24 VDC.
- 4 Position feedback cannot be used with Triac sink controller. The actuator internal common reference is not compatible.
- 5 Control signal may be pulsed from either the Hot (source) or the Common (sink) 24 VAC line.
- 8 Contact closures A & B also can be triacs.
- 9 A & B should both be closed for triac source and open for triac sink.
- 9 For triac sink the common connection from the actuator must be connected to the hot connection of the controller.

APPLICATION NOTES

- ◆ The ZG-R01 500 Ω resistor may be used.

WARNING Live Electrical Components!

During installation, testing, servicing and troubleshooting of this product, it may be necessary to work with live electrical components. Have a qualified licensed electrician or other individual who has been properly trained in handling live electrical components perform these tasks. Failure to follow all electrical safety precautions when exposed to live electrical components could result in death or serious injury.

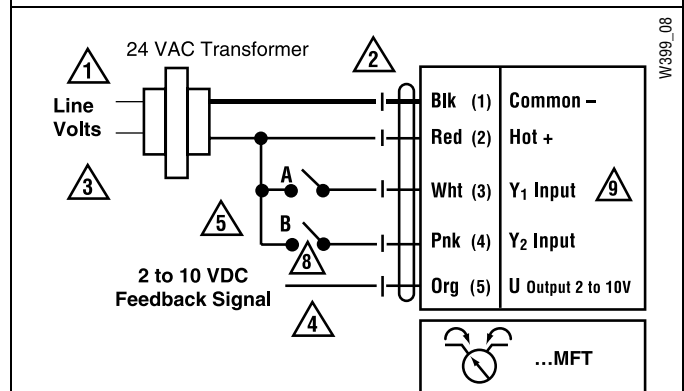
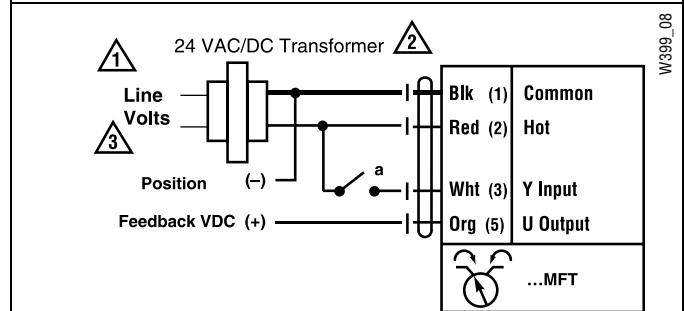
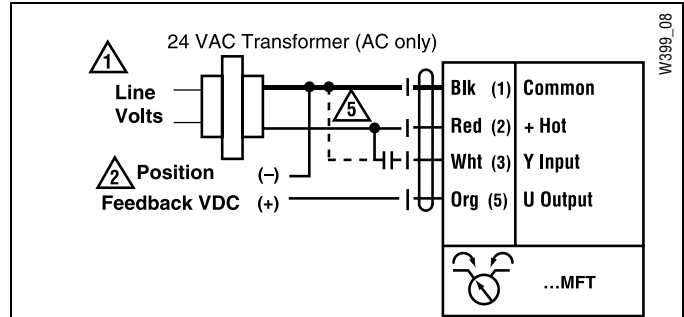
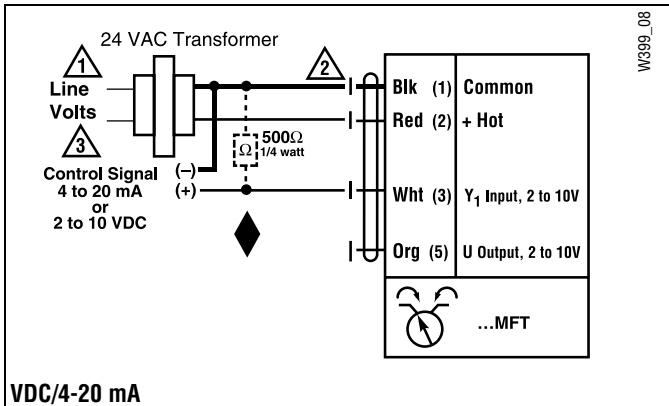

ith actuator types ... MFT

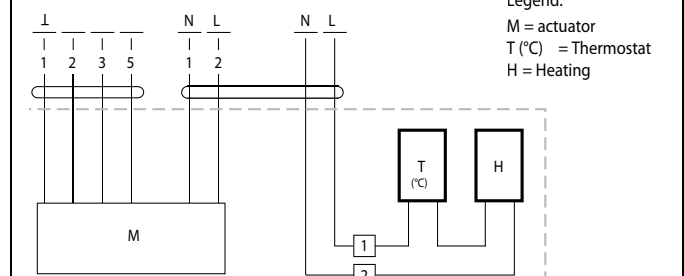

Note
The following points must be taken into account with independent, external wiring:

- All contact between the cables or wires that are introduced and the heating element is to be avoided.
- Where necessary, use cables with sufficient numbers of wires, e.g. so that the heating and the actuator can be supplied separately with voltage.

AMCX24-MFT

Proportional, Non-Spring Return, 24 V, Multi-Function Technology®



MFT



Technical Data	AMCX24-MFT
Power supply	24 VAC ± 20% 50/60 Hz 24 VDC ± 10%
Power consumption	4 W (1.25 W)
Transformer sizing	6 VA (Class 2 power source)
Electrical connection	18 GA plenum rated cable 1/2" conduit connector protected NEMA 2 (IP54) 3 ft [1m] 10 ft [3m] 16 ft [5m]
Overload protection	electronic throughout 0 to 95° rotation
Operating range Y	2 to 10 VDC, 4 to 20 mA (default) variable (VDC, PWM, floating point, on/off)
Input impedance	100 kΩ (0.1 mA), 500 Ω 1500 W (PWM, floating point, on/off)
Feedback output U	2 to 10 VDC, 0.5 mA max VDC variable
Angle of rotation	max. 95°, adjustable with mechanical stop electronically variable
Torque	180 in-lb [20 Nm]
Direction of rotation	reversible with switch
Position indication	reflective visual indicator (snap-on)
Manual override	external push button
Running time	35 seconds (default) variable (35 to 120 seconds)
Humidity	5 to 95% RH non condensing (EN 60730-1)
Ambient temperature	-22°F to 122°F [-30°C to 50°C]
Storage temperature	-40°F to 176°F [-40°C to 80°C]
Housing	NEMA 2, IP54, UL enclosure type 2
Housing material	UL94-5VA
Agency listings†	cULus acc. to UL 60730-1A/-2-14, CAN/CSA E60730-1:02, CE acc. to 2004/108/EEC and 2006/95/EC
Noise level	<45dB(A)
Servicing	maintenance free
Quality standard	ISO 9001
Weight	2.6 lbs [1.2 kg]

Torque min. 180 in-lb for control of damper surfaces up to 45 sq ft.

Application

For proportional modulation of dampers in HVAC systems. Actuator sizing should be done in accordance with the damper manufacturer's specifications.

The actuator is mounted directly to a damper shaft up to 1.05" in diameter by means of its universal clamp, 1/2" self-centered default. A crank arm and several mounting brackets are available for applications where the actuator cannot be direct coupled to the damper shaft.

The default parameters for 2 to 10 VDC applications of the ...MFT actuator are assigned during manufacturing. If necessary, custom versions of the actuators can be ordered. The parameters can be changed by two means: pre-set and custom configurations from Belimo or on-site configurations using the Belimo PC-Tool software.

Operation

The actuator is not provided with and does not require any limit switches, but is electronically protected against overload. The anti-rotation strap supplied with the actuator will prevent lateral movement.

The AMX series provides 95° of rotation and a visual indicator indicates position of the actuator. When reaching the damper or actuator end position, the actuator automatically stops. The gears can be manually disengaged with a button on the actuator cover.

The AMCX24-MFT actuators use a brushless DC motor, which is controlled by an Application Specific Integrated Circuit (ASIC). The ASIC monitors and controls the actuator's rotation and provides a digital rotation sensing (DRS) function to prevent damage to the actuator in a stall condition. Power consumption is reduced in holding mode.

Add-on auxiliary switches or feedback potentiometers are easily fastened directly onto the actuator body for signaling and switching functions

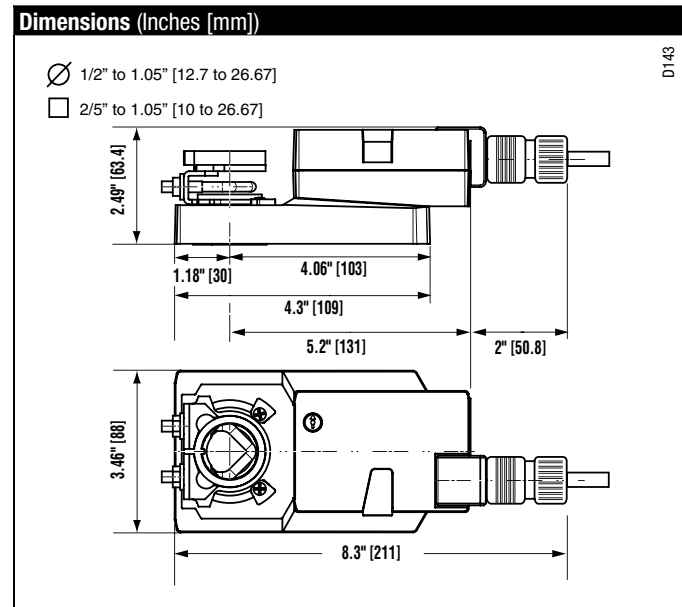

IM40024 - 05/10 - Subject to change. © Belimo Aircontrols (USA), Inc.

Accessories

K-SA	Reversible Clamp
ZG-100	Universal Mounting Bracket
ZG-101	Universal Mounting Bracket
ZG-103	Universal Mounting Bracket
ZG-104	Universal Mounting Bracket
Z-SMA	AM/SM to AM Retrofit Mounting Bracket
ZG-AMA	Crank arm Adaptor Kit
AV8-25	Universal Shaft Extension
ZG-JSA (-1, 2, 3)	Jackshaft Adaptors for Hollow Jackshafts
ZS-100	Weather Shield - Steel
ZS-150	Weather Shield - Polycarbonate
ZS-260	Explosion Proof Housing
ZS-300 (-1) (-5)	NEMA 4X Housing
Tool-06	8 mm & 10 mm Wrench
S1A, S2A	Auxiliary Switch(es)
P370	Shaft Mount Auxiliary Switch
P...A	Feedback Potentiometers
SGA24	Min positioners in NEMA 4 housing
SGF24	Min positioners for flush panel mounting
ADS-100	Analog to Digital Switch
ZG-R01	Resistor for 4 to 20 mA Conversion
NSV24	US Battery Back-Up Module
ZG-X40	Transformer

Note: When using AMCX24-MFT... actuators, only use accessories listed on this page.

Typical Specification

Proportional control damper actuators shall be electronic direct coupled type, which require no crank arm and linkage and be capable of direct mounting to a shaft up to 1.05" diameter. Actuators must provide proportional damper control in response to a 2 to 10 VDC or, with the addition of a 500 Ω resistor, a 4 to 20 mA control input from an electronic controller or positioner. Actuators shall have brushless DC motor technology and be protected from overload at all angles of rotation. Actuators shall have reversing switch and manual override on the cover. Run time shall be constant and independent of torque. Actuators shall be cULus listed, have a 5-year warranty, and be manufactured under ISO 9001 International Quality Control Standards. Actuators shall be as manufactured by Belimo.

Wiring Diagrams

✂️ INSTALLATION NOTES

- 1 Provide overload protection and disconnect as required.
- 2 **CAUTION Equipment Damage!** Actuators may be connected in parallel if not mechanically mounted to the same shaft. Power consumption and input impedance must be observed.
- 3 Actuators may also be powered by 24 VDC.
- 4 Position feedback cannot be used with Triac sink controller. The actuator internal common reference is not compatible.
- 5 Control signal may be pulsed from either the Hot (source) or the Common (sink) 24 VAC line.
- 8 Contact closures A & B also can be triacs.
- 9 For triac sink the common connection from the actuator must be connected to the hot connection of the controller.

📄 APPLICATION NOTES

- ◆ The ZG-R01 500 Ω resistor may be used.

⚠️ WARNING Live Electrical Components!

During installation, testing, servicing and troubleshooting of this product, it may be necessary to work with live electrical components. Have a qualified licensed electrician or other individual who has been properly trained in handling live electrical components perform these tasks. Failure to follow all electrical safety precautions when exposed to live electrical components could result in death or serious injury.

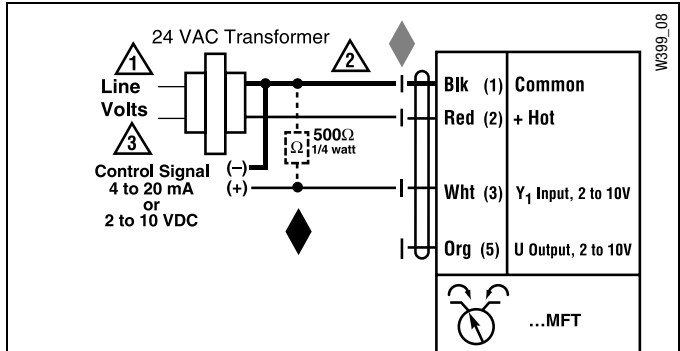

VDC/4-20 mA

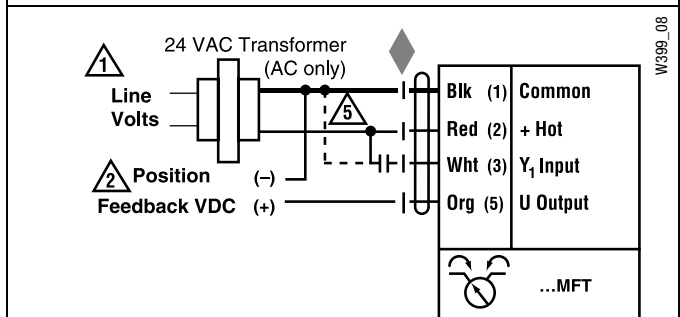

PWM

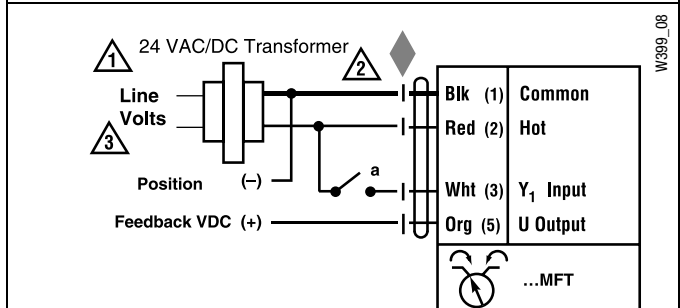

On/Off control

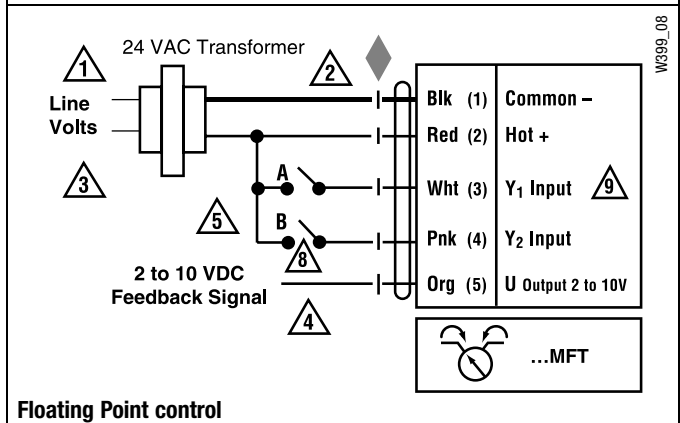

Floating Point control

AMX24-MFT95

Proportional, Non-Spring Return, 24 V, 0 to 135 Ω Input



MFT



Technical Data	AMX24-MFT95
Power supply	24 VAC ± 20% 50/60 Hz 24 VDC ± 10%
Power consumption	3.5 W (1.3 W)
Transformer sizing	6 VA (Class 2 power source)
Electrical connection	18 GA plenum rated cable 1/2" conduit connector protected NEMA 2 (IP54) 3 ft [1m] 10 ft [3m] 16 ft [5m]
Overload protection	electronic throughout 0 to 95° rotation
Operating range WRB	135 Ω Honeywell Electronic Series 90, 0 to 135 Ω input
Feedback output U	2 to 10 VDC, 0.5 mA max
Angle of rotation	max. 95°, adjustable with mechanical stop electronically variable
Torque	180 in-lb [20 Nm]
Direction of rotation	reversible with switch
Position indication	reflective visual indicator (snap-on)
Manual override	external push button
Running time	150 seconds (default) variable (90 to 350 seconds)
Humidity	5 to 95% RH non condensing (EN 60730-1)
Ambient temperature	-22°F to 122°F [-30°C to 50°C]
Storage temperature	-40°F to 176°F [-40°C to 80°C]
Housing	NEMA 2, IP54, UL enclosure type 2
Housing material	UL94-5VA
Agency listings†	cULus acc. to UL 60730-1A/-2-14, CAN/CSA E60730-1:02, CE acc. to 2004/108/EEC and 2006/95/EC
Noise level	<45dB(A)
Servicing	maintenance free
Quality standard	ISO 9001
Weight	2.6 lbs [1.2 kg]

† Rated Impulse Voltage 800V, Type of action 1.AA, Control Pollution Degree 3.

Torque min. 180 in-lb for control of damper surfaces up to 45 sq ft.

Application

For proportional modulation of dampers in HVAC systems. Actuator sizing should be done in accordance with the damper manufacturer's specifications.

The actuator is mounted directly to a damper shaft up to 1.05" in diameter by means of its universal clamp, 1/2" self-centered default. A crank arm and several mounting brackets are available for applications where the actuator cannot be direct coupled to the damper shaft.

The default parameters for 0 to 135 Ω input applications of the ...MFT95 actuator are assigned during manufacturing. If necessary, custom versions of the actuators can be ordered. The parameters can be changed by two means: pre-set and custom configurations from Belimo or on-site configurations using the Belimo PC-Tool software.

Operation

The actuator is not provided with and does not require any limit switches, but is electronically protected against overload. The anti-rotation strap supplied with the actuator will prevent lateral movement.

The AMX series provides 95° of rotation and a visual indicator indicates position of the actuator. When reaching the damper or actuator end position, the actuator automatically stops. The gears can be manually disengaged with a button on the actuator cover.

The AMX24-MFT95 actuators use a brushless DC motor, which is controlled by an Application Specific Integrated Circuit (ASIC). The ASIC monitors and controls the actuator's rotation and provides a digital rotation sensing (DRS) function to prevent damage to the actuator in a stall condition. Power consumption is reduced in holding mode.

Add-on auxiliary switches or feedback potentiometers are easily fastened directly onto the actuator body for signaling and switching functions.

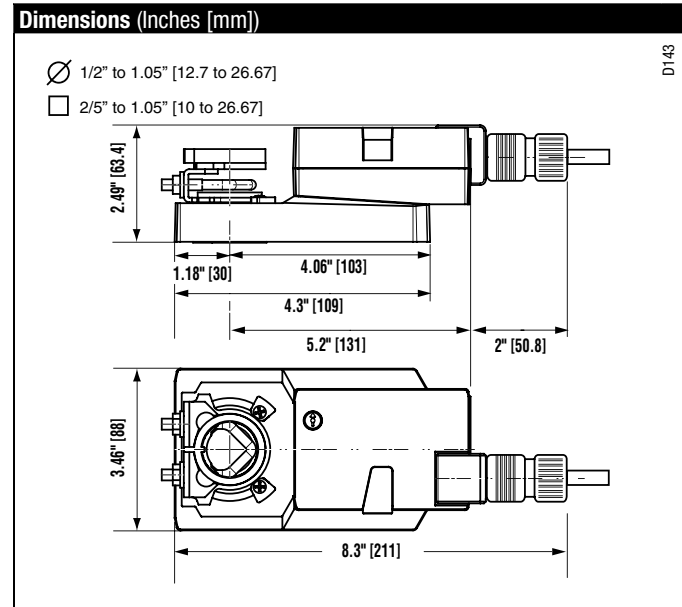

IM40024 - 05/10 - Subject to change. © Belimo Aircontrols (USA), Inc.

Accessories

K-SA	Reversible Clamp
ZG-100	Universal Mounting Bracket
ZG-101	Universal Mounting Bracket
ZG-103	Universal Mounting Bracket
ZG-104	Universal Mounting Bracket
Z-SMA	AM/SM to AM Retrofit Mounting Bracket
ZG-AMA	Crank arm Adaptor Kit
AV8-25	Universal Shaft Extension
ZG-JSA (-1, 2, 3)	Jackshaft Adaptors for Hollow Jackshafts
ZS-100	Weather Shield - Steel
ZS-150	Weather Shield - Polycarbonate
ZS-260	Explosion Proof Housing
ZS-300 (-1) (-5)	NEMA 4X Housing
Tool-06	8 mm & 10 mm Wrench
S1A, S2A	Auxiliary Switch (es)
P370	Shaft Mount Auxiliary Switch
P...A	Feedback Potentiometers
NSV24 US	Battery Back-Up Module
ZG-X40	Transformer

NOTE: When using AMX24-MFT95... actuators, only use accessories listed on this page.

Typical Specification

Proportional control damper actuators shall be electronic direct-coupled type, which require no crank arm and linkage and be capable of direct mounting to a shaft up to 1.05" diameter. Actuators must provide proportional damper control in response to 0 to 135 Ω control input from an electronic controller or positioner. Actuators shall have brushless DC motor technology and be protected from overload at all angles of rotation. Actuators shall have reversing switch and manual override on the cover. Run time shall be constant and independent of torque. Actuators shall be cULus listed, have a 5-year warranty, and be manufactured under ISO 9001 International Quality Control Standards. Actuators shall be as manufactured by Belimo.

Wire Colors

1 = Black	3 = White	5 = Gray
2 = Red	4 = Pink	6 = Orange

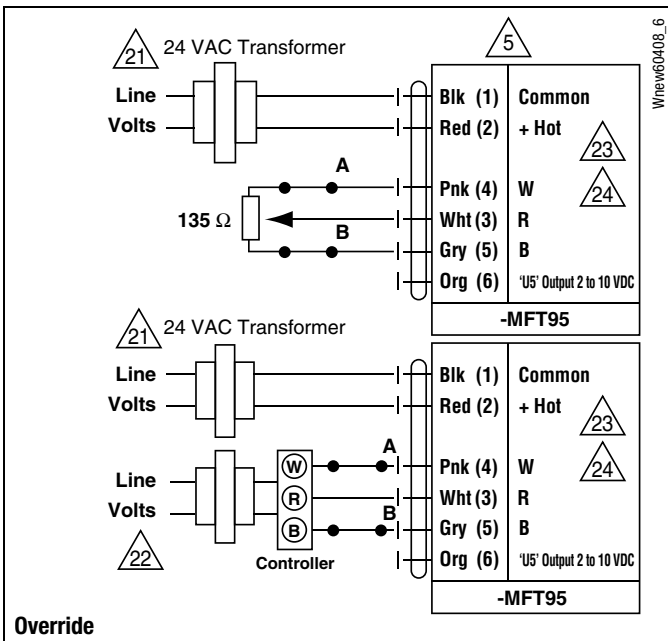

Wiring Diagrams

INSTALLATION NOTES

- △5 Actuators with plenum rated cable do not have numbers on wires; use color codes instead. Actuators with appliance cables are numbered.
- △21 Provide overload protection and disconnect as required.
- △22 Actuators and controller must have separate transformers.
- △23 Consult controller instruction data for more detailed information.
- △24 Resistor value depends on the type of controller and the number of actuators. No resistor is used for one actuator. Honeywell® resistor kits may also be used.
- △25 To reverse control rotation, use the reversing switch.

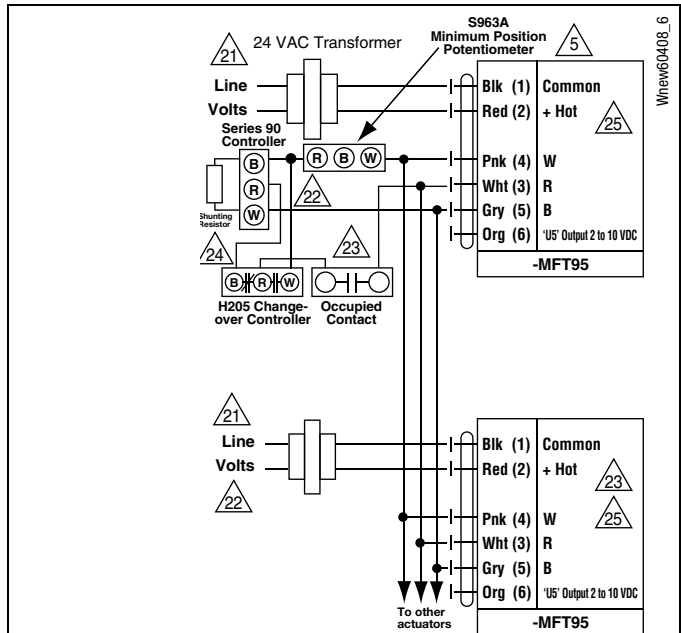

Wiring multiple actuators to a Series 90 controller using a minimum position potentiometer.

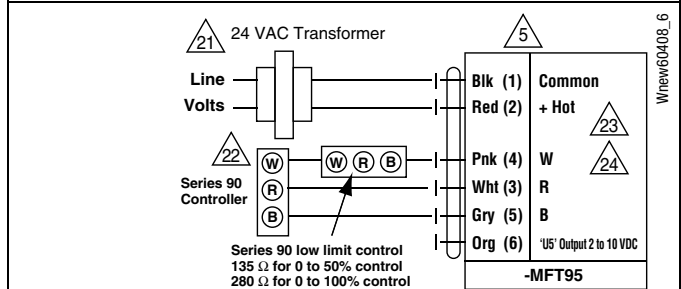

Low Limit Control

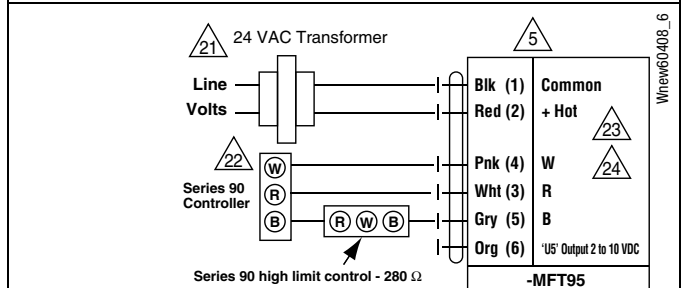

High Limit Control

AMX24-PC

Proportional, Non-Spring Return, 24 V, 0 to 20V Phasecut



Technical Data	AMX24-PC
Power supply	24 VAC \pm 20% 50/60 Hz 24 VDC \pm 10%
Power consumption	3.5 W (1.3 W)
Transformer sizing	5.5 VA (Class 2 power source)
Electrical connection	18 GA plenum rated cable 1/2" conduit connector protected NEMA 2 (IP54) 3 ft [1m] 10 ft [3m] 16 ft [5m]
Overload protection	electronic throughout 0 to 95° rotation
Operating range Y	0 to 20 V phasecut Control is only for the positive part of the sine wave (max of 10 volts)
Input impedance	8 k Ω (50 mW)
Feedback output U	2 to 10 VDC, 0.5 mA max VDC variable
Angle of rotation	max. 95°, adjustable with mechanical stop electronically variable
Torque	180 in-lb [20 Nm]
Direction of rotation	reversible with switch
Position indication	reflective visual indicator (snap-on)
Manual override	external push button
Running time	150 seconds (default)
Humidity	5 to 95% RH non condensing (EN 60730-1)
Ambient temperature	-22°F to 122°F [-30°C to 50°C]
Storage temperature	-40°F to 176°F [-40°C to 80°C]
Housing	NEMA 2, IP54, UL enclosure type 2
Housing material	UL94-5VA
Agency listings†	cULus acc. to UL 60730-1A/-2-14, CAN/CSA E60730-1:02, CE acc. to 2004/108/EEC and 2006/95/EC
Noise level	<45dB(A)
Servicing	maintenance free
Quality standard	ISO 9001
Weight	2.6 lbs [1.2 kg]

†Rated Impulse Voltage 800V, Type of action 1, Control Pollution Degree 3.

Torque min. 180 in-lb for control of damper surfaces up to 45 sq ft.

Application

For proportional modulation of dampers in HVAC systems. Actuator sizing should be done in accordance with the damper manufacturer's specifications.

The actuator is mounted directly to a damper shaft up to 1.05" in diameter by means of its universal clamp, 1/2" self-centered default. A crank arm and several mounting brackets are available for applications where the actuator cannot be direct coupled (only the positive part of the sine wave) to the damper shaft.

The actuator operates in response to 0 to 20V phasecut control input only on the positive part of the sine wave from an electronic controller or positioner. A 2 to 10 VDC feedback signal is provided for position indication.

Operation

The actuator is not provided with and does not require any limit switches, but is electronically protected against overload. The anti-rotation strap supplied with the actuator will prevent lateral movement.

The AMX series provides 95° of rotation and a visual indicator indicates position of the actuator. When reaching the damper or actuator end position, the actuator automatically stops. The gears can be manually disengaged with a button on the actuator cover.

The AMX24-PC actuators use a brushless DC motor, which is controlled by an Application Specific Integrated Circuit (ASIC). The ASIC monitors and controls the actuator's rotation and provides a digital rotation sensing (DRS) function to prevent damage to the actuator in a stall condition. Power consumption is reduced in holding mode.

Add-on auxiliary switches or feedback potentiometers are easily fastened directly onto the actuator body for signaling and switching functions.

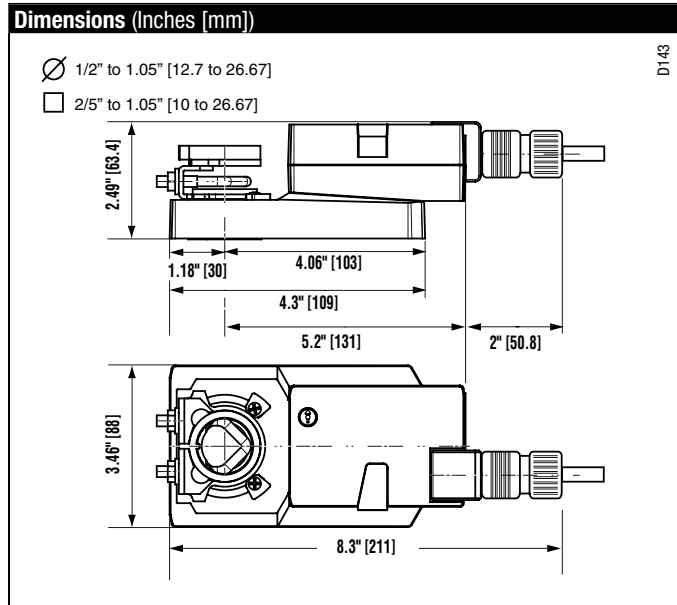

IM40024 - 05/10 - Subject to change. © Belimo Aircontrols (USA), Inc.

Accessories	
K-SA	Reversible Clamp
ZG-100	Universal Mounting Bracket
ZG-101	Universal Mounting Bracket
ZG-103	Universal Mounting Bracket
ZG-104	Universal Mounting Bracket
Z-SMA	AM/SM to AM Retrofit Mounting Bracket
ZG-AMA	Crank arm Adaptor Kit
AV8-25	Universal Shaft Extension
ZG-JSA (-1, 2, 3)	Jackshaft Adaptors for Hollow Jackshafts
ZS-100	Weather Shield - Steel
ZS-150	Weather Shield - Polycarbonate
ZS-260	Explosion Proof Housing
ZS-300 (-1) (-5)	NEMA 4X Housing
Tool-06	8 mm & 10 mm Wrench
S1A, S2A	Auxiliary Switch (es)
P370	Shaft Mount Auxiliary Switch
P...A	Feedback Potentiometers
NSV24 US	Battery Back-Up Module
ZG-X40	Transformer

NOTE: When using AMX24-PC... actuators, only use accessories listed on this page.

Typical Specification

Proportional control damper actuators shall be electronic direct-coupled type, which require no crank arm and linkage and be capable of direct mounting to a shaft up to 1.05" diameter. Actuators must provide proportional damper control in response to 0 to 20V phasecut control input from an electronic controller or positioner. Actuators shall have brushless DC motor technology and be protected from overload at all angles of rotation. Actuators shall have reversing switch and manual override on the cover. Run time shall be constant and independent of torque. Actuators shall be cULus listed, have a 5-year warranty, and be manufactured under ISO 9001 International Quality Control Standards. Actuators shall be as manufactured by Belimo.

Wiring Diagram

✂️ INSTALLATION NOTES

- 1 Provide overload protection and disconnect as required.
- 2 **CAUTION Equipment Damage!**
Actuators may be connected in parallel.
Power consumption and input impedance must be observed.
- 3 Actuators may also be powered by 24 VDC.

⚠️ WARNING Live Electrical Components!
During installation, testing, servicing and troubleshooting of this product, it may be necessary to work with live electrical components. Have a qualified licensed electrician or other individual who has been properly trained in handling live electrical components perform these tasks. Failure to follow all electrical safety precautions when exposed to live electrical components could result in death or serious injury.

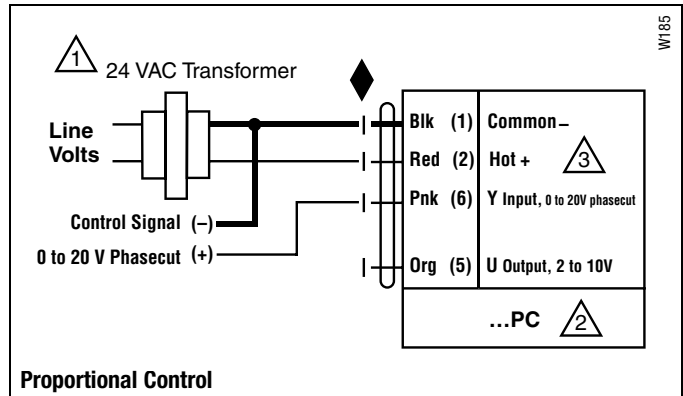

AMQB(X)24-1

On/Off, Non-Spring Return, 24 V



Technical Data	AMQB(X)24-1
Power supply	24 VAC $\pm 20\%$ 50/60 Hz 24 VDC $\pm 10\%$
Power consumption	15 W (1.5 W)
Transformer sizing	26 VA (Class 2 power source)
Electrical connection	3 ft [1m] 10 ft [3m] 16 ft [5m] 18 GA plenum rated cable protected NEMA 2 (IP54)
Overload protection	electronic throughout 0 to 95° rotation
Control	on/off
Input impedance	1000 Ω
Angle of rotation	min. 30°, max. 95°, adjust. with mechanical stop
Torque	140 in-lb [16 Nm]
Direction of rotation	reversible with switch
Position indication	reflective visual indicator (snap-on)
Manual override	external push button
Running time	7, 10, 15 or 20 seconds constant independent of load
Humidity	5 to 95% RH non-condensing (EN 60730-1)
Ambient temperature	-22°F to 122°F [-30°C to 50°C]
Storage temperature	-40°F to 176°F [-40°C to 80°C]
Housing	NEMA 2, IP54, UL enclosure type 2
Housing material	UL94-5VA
Agency listings	cULus acc. to UL 60730-1A/-2-14, CAN/CSA E60730-1:02, CE acc. to 2004/108/EEC and 2006/95/EC
Noise level	<52 dB(A)
Servicing	maintenance free
Quality standard	ISO 9001
Weight	3.75 lbs [1.7 kg]

Rated Impulse Voltage 800V, Type of action 1, Control Pollution Degree 3.

Torque min. 140 in-lb for control of damper surfaces up to 35 sq ft.

Application

For On/Off control of dampers in HVAC systems. Actuator sizing should be done in accordance with the damper manufacturer's specifications.

The actuator is mounted directly to a damper shaft up to 1.05" in diameter by means of its universal clamp, self-centered default. A crank arm and several mounting brackets are available for applications where the actuator cannot be direct coupled to the damper shaft.

Operation

The actuator is not provided with and does not require any limit switches, but is electronically protected against overload. The anti-rotation strap supplied with the actuator will prevent lateral movement.

The AMQB(X) series provides 95° of rotation and a visual indicator indicates position of the actuator. When reaching the damper or actuator end position, the actuator automatically stops. The gears can be manually disengaged with a button on the actuator cover.

The AMQB(X)24-1 actuators use a sensorless brushless DC motor, which is controlled by an Application Specific Integrated Circuit (ASIC). The ASIC monitors and controls the actuator's rotation and provides a digital rotation sensing (DRS) function to prevent damage to the actuator in a stall condition. Power consumption is reduced in holding mode.

Add-on auxiliary switches or feedback potentiometers are easily fastened directly onto the actuator body for signaling and switching functions.

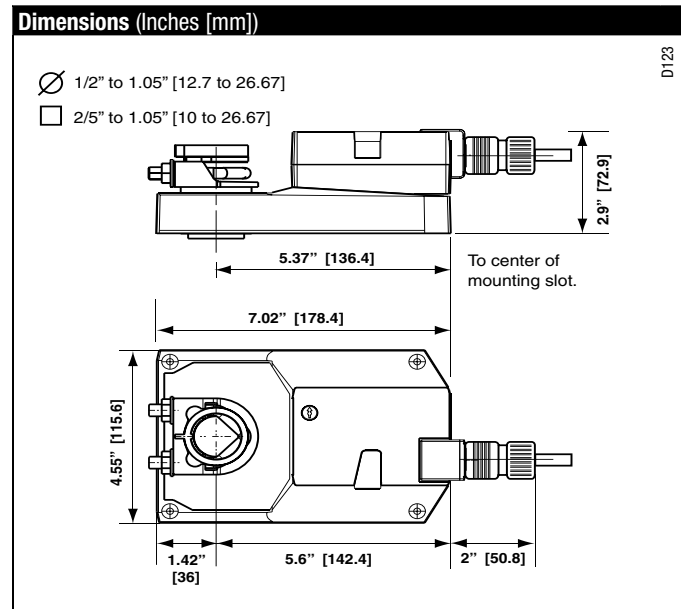

IM40024 - 05/10 - Subject to change. © Belimo Aircontrols (USA), Inc.

Accessories	
K-GM20	½" -1.05" Shaft Clamp
ZG-100	Universal Mounting Bracket
ZG-102	Universal Mounting Bracket
Z-GMA	Retrofit Mounting Bracket
ZG-NMA	Crank arm Adaptor Kit
AV8-25	Universal Shaft Extension
ZG-JSA (-1, 2, 3)	Jackshaft Adaptors for Hollow Jackshafts
ZS-100	Weather Shield - Steel
ZS-150	Weather Shield - Polycarbonate
ZS-260	Explosion Proof Housing
ZS-300 (-1) (-5)	NEMA 4X Housing
Tool-06	8 mm & 10 mm Wrench
PS-100	Actuator Power Supply Simulator
S1A, S2A	Auxiliary Switch (es)
P370	Shaft Mount Auxiliary Switch
P...A	Feedback Potentiometers

NOTE: When using AMQB(X)24-1 actuators, only use accessories listed on this page.

Typical Specification

On/Off control damper actuators shall be electronic direct-coupled type, which require no crank arm and linkage and be capable of direct mounting to a shaft up to 1.05" diameter. Actuators shall have brushless DC motor technology and be protected from overload at all angles of rotation. Actuators shall have reversing switch and manual override on the cover. Run time shall be constant and independent of torque. Actuators shall be cULus listed, have a 5-year warranty, and be manufactured under ISO 9001 International Quality Control Standards. Actuators shall be as manufactured by Belimo.

Wiring Diagram

INSTALLATION NOTES

- 1 Provide overload protection and disconnect as required.
- 3 Actuators may also be powered by 24 VDC.

APPLICATION NOTES

- Meets cULus or UL and CSA Standard requirements without the need of an electrical ground connection.

WARNING Live Electrical Components!

During installation, testing, servicing and troubleshooting of this product, it may be necessary to work with live electrical components. Have a qualified licensed electrician or other individual who has been properly trained in handling live electrical components perform these tasks. Failure to follow all electrical safety precautions when exposed to live electrical components could result in death or serious injury.

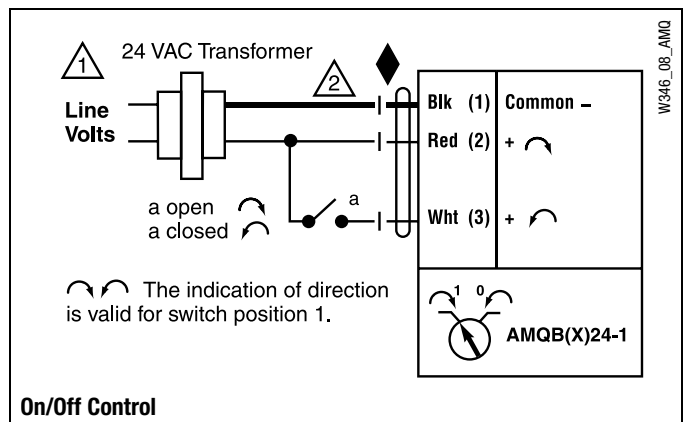

AMQB(X)24-MFT

Proportional, Non-Spring Return, 24 V, Multi-Function Technology®



MFT



Technical Data	AMQB(X)24-MFT
Power supply	24 VAC ± 20% 50/60 Hz 24 VDC ± 10%
Power consumption	15 W (1.5 W)
Transformer sizing	26 VA (Class 2 power source)
Electrical connection	3 ft [1m] 10 ft [3m] 16 ft [5m] 18 GA plenum rated cable protected NEMA 2 (IP54)
Overload protection	electronic throughout 0 to 95° rotation
Operating range Y	2 to 10 VDC, 4 to 20 mA (default) variable (VDC, on/off)
Input impedance	100 kΩ (0.1 mA), 500 Ω, 1000 Ω (on/off)
Feedback output U	2 to 10 VDC, 0.5 mA max, VDC variable
Angle of rotation	min. 30°, max. 95°, adjust. with mechanical stop electronically variable
Torque	140 in-lb [16 Nm]
Direction of rotation	reversible with switch
Position indication	reflective visual indicator (snap-on)
Manual override	external push button
Running time	7, 10, 15 or 20 seconds constant independent of load
Humidity	5 to 95% RH non condensing (EN 60730-1)
Ambient temperature	-22°F to 122°F [-30°C to 50°C]
Storage temperature	-40°F to 176°F [-40°C to 80°C]
Housing	NEMA 2, IP54, UL enclosure type 2
Housing material	UL94-5VA
Agency listings†	cULus acc. to UL 60730-1A/-2-14, CAN/CSA E60730-1:02, CE acc. to 2004/108/EEC and 2006/95/EC
Noise level	<52dB(A)
Servicing	maintenance free
Quality standard	ISO 9001
Weight	3.75 lbs [1.7 kg]

†Rated Impulse Voltage 800V, Type of action 1, Control Pollution Degree 3.

Torque min. 140 in-lb for control of damper surfaces up to 35 sq ft.

Application

For proportional modulation of dampers in HVAC systems. Actuator sizing should be done in accordance with the damper manufacturer's specifications.

The actuator is mounted directly to a damper shaft up to 1.05" in diameter by means of its universal clamp, 1/2" self-centered default. A crank arm and several mounting brackets are available for applications where the actuator cannot be direct coupled to the damper shaft.

The default parameters for 2 to 10 VDC applications of the ...MFT actuator are assigned during manufacturing. If necessary, custom versions of the actuators can be ordered. The parameters can be changed by two means: pre-set and custom configurations from Belimo or on-site configurations using the Belimo PC-Tool software.

Operation

The actuator is not provided with and does not require any limit switches, but is electronically protected against overload. The anti-rotation strap supplied with the actuator will prevent lateral movement.

The AMQB(X) series provides 95° of rotation and a visual indicator indicates position of the actuator. When reaching the damper or actuator end position, the actuator automatically stops. The gears can be manually disengaged with a button on the actuator cover.

The AMQB(X)24-MFT actuators use a brushless DC motor, which is controlled by an Application Specific Integrated Circuit (ASIC). The ASIC monitors and controls the actuator's rotation and provides a digital rotation sensing (DRS) function to prevent damage to the actuator in a stall condition. Power consumption is reduced in holding mode.

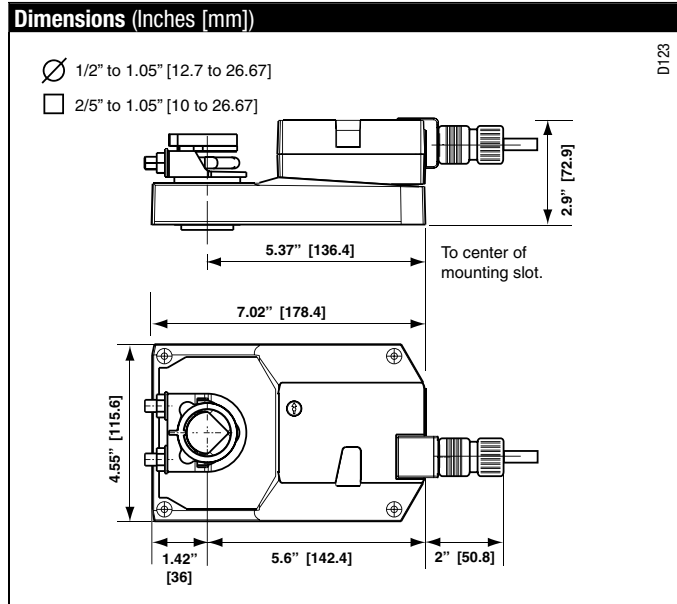

IM40024 - 05/10 - Subject to change. © Belimo Aircontrols (USA), Inc.

Accessories	
K-GM20	½"-1.05 Shaft Clamp
ZG-100	Universal Mounting Bracket
ZG-102	Universal Mounting Bracket
Z-GMA	Retrofit Mounting Bracket
ZG-AMA	Crank arm Adaptor Kit
AV8-25	Universal Shaft Extension
ZG-JSA (-1, 2, 3)	Jackshaft Adaptors for Hollow Jackshafts
ZS-100	Weather Shield - Steel
ZS-150	Weather Shield - Polycarbonate
ZS-260	Explosion Proof Housing
ZS-300 (-1) (-5)	NEMA 4X Housing
Tool-06	8 mm & 10 mm Wrench
S1A, S2A	Auxiliary Switch (es)
P370	Shaft Mount Auxiliary Switch
P...A	Feedback Potentiometers
SGA24	Min positioners in NEMA 4 housing
SGF24	Min positioners for flush panel mounting
ADS-100	Analog to Digital Switch
ZG-R01	Resistor for 4 to 20 mA Conversion
NSV24 US	Battery Back-Up Module
ZG-X40	Transformer

NOTE: When using AMQB(X)24-MFT actuators, only use accessories listed on this page.

Typical Specification

Proportional control damper actuators shall be electronic direct-coupled type, which require no crank arm and linkage and be capable of direct mounting to a shaft up to 1.05" diameter. Actuators must provide proportional damper control in response to a 2 to 10 VDC or, with the addition of a 500 Ω resistor, a 4 to 20 mA control input from an electronic controller or positioner. Actuators shall have brushless DC motor technology and be protected from overload at all angles of rotation. Actuators shall have reversing switch and manual override on the cover. Run time shall be constant and independent of torque. Actuators shall be cULus listed, have a 5-year warranty, and be manufactured under ISO 9001 International Quality Control Standards. Actuators shall be as manufactured by Belimo.

Wiring Diagrams

INSTALLATION NOTES

- 1 Provide overload protection and disconnect as required.
- 2 **CAUTION Equipment Damage!**
Actuators may be connected in parallel if not mechanically mounted to the same shaft. Power consumption and input impedance must be observed.
- 3 Actuators may also be powered by 24 VDC.

APPLICATION NOTES

- ◆ The ZG-R01 500 Ω resistor may be used.

WARNING Live Electrical Components!

During installation, testing, servicing and troubleshooting of this product, it may be necessary to work with live electrical components. Have a qualified licensed electrician or other individual who has been properly trained in handling live electrical components perform these tasks. Failure to follow all electrical safety precautions when exposed to live electrical components could result in death or serious injury.

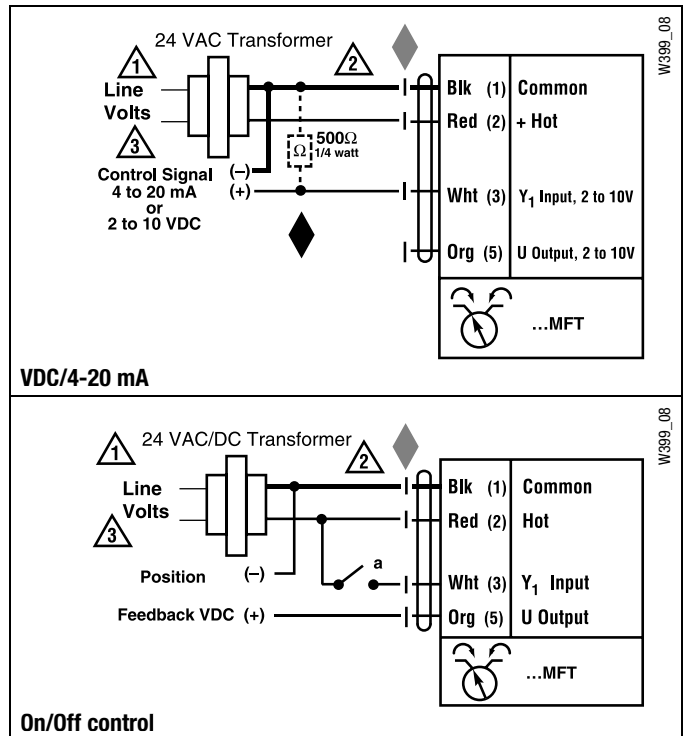

AMX24-LON

LonWorks®, Non-Spring Return, 24 V



Technical Data	AMX24-LON
Power supply	24 VAC ± 20% 50/60 Hz 24 VDC ± 10%
Power consumption	3.5 W (1.3 W)
Transformer sizing	6 VA (Class 2 power source)
Electrical connection	18 GA plenum rated cable 1/2" conduit connector protected NEMA 2 (IP54) 3 ft [1m]
Overload protection	electronic throughout 0 to 95° rotation
Angle of rotation	max. 95°, adjustable with mechanical stop electronically variable
Torque	180 in-lb [20 Nm]
Direction of rotation	reversible with switch
Position indication	reflective visual indicator (snap-on)
Manual override	external push button
Running time	150 seconds (default)
Humidity	5 to 95% RH non condensing (EN 60730-1)
Ambient temperature	-22°F to 122°F [-30°C to 50°C]
Storage temperature	-40°F to 176°F [-40°C to 80°C]
Housing	NEMA 2, IP54, UL enclosure type 2
Housing material	UL94-5VA
Agency listings†	cULus acc. to UL 60730-1A/-2-14, CAN/CSA E60730-1:02, CE acc. to 2004/108/EEC and 2006/95/EC
Noise level	<45dB(A)
Servicing	maintenance free
Quality standard	ISO 9001
Weight	2.6 lbs [1.2 kg]

†Rated Impulse Voltage 800V, Type of action 1, Control Pollution Degree 3.

LonWorks®	
Certified	according to LonMARK® 3.3
Processor	Neuron 3120
Transceiver	FTT-10A, compatible with LPT-10
Functional profile	according to LonMARK® damper actuator object #8110 open loop sensor object #1
LNS plug-in for actuator/sensor	can be run with any LNS based integration tool (min. for LNS 3.x)
Service button and status LED	according to LonMARK® guidelines
Conductors, cables	conductor lengths, cable specifications and topology of the LonWorks® network according to the Echelon® directives

LonWorks and LonMARK © 2007-2009 LonMark International

Torque min. 180 in-lb for control of damper surfaces up to 45 sq ft.

Application

Direct coupled actuators for direct link to LonWorks network. Actuators are easily installed by direct shaft mounting on air dampers in ventilation and air conditioning systems. Actuator can be controlled by any compatible LON system.

For proportional modulation of dampers in HVAC systems. Actuator sizing should be done in accordance with the damper manufacturer's specifications.

The actuator is mounted directly to a damper shaft up to 1.05" in diameter by means of its universal clamp, 1/2" self-centered default. A crank arm and several mounting brackets are available for applications where the actuator cannot be direct coupled to the damper shaft.

Operation

The actuator is not provided with and does not require any limit switches, but is electronically protected against overload. The anti-rotation strap supplied with the actuator will prevent lateral movement.

The AMX24-LON series provides 95° of rotation and a visual indicator indicates position of the actuator. When reaching the damper or actuator end position, the actuator automatically stops. The gears can be manually disengaged with a button on the actuator cover.

The AMX24-LON actuators use a brushless DC motor, which is controlled by an Application Specific Integrated Circuit (ASIC). The ASIC monitors and controls the actuator's rotation and provides a digital rotation sensing (DRS) function to prevent damage to the actuator in a stall condition. Power consumption is reduced in holding mode.

Add-on auxiliary switches or feedback potentiometers are easily fastened directly onto the actuator body for signaling and switching functions.

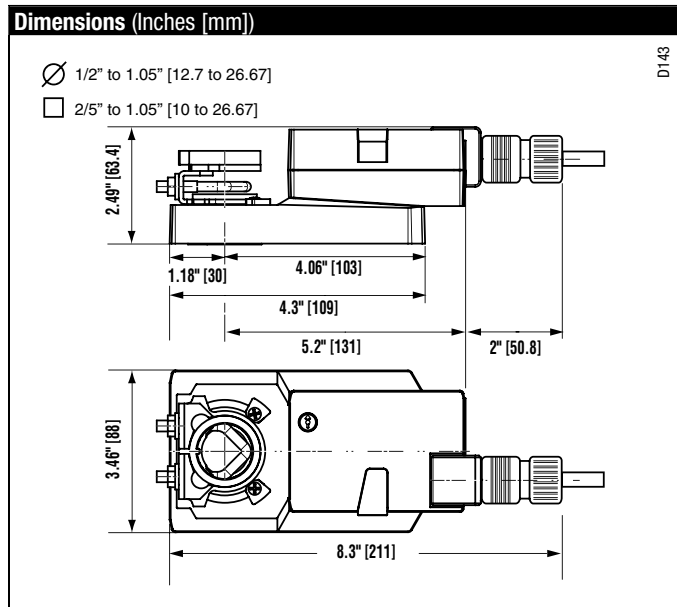

M40024 - 05/10 - Subject to change. © Belimo Aircontrols (USA), Inc.

Accessories

K-SA	Reversible Clamp
ZG-100	Universal Mounting Bracket
ZG-101	Universal Mounting Bracket
ZG-103	Universal Mounting Bracket
ZG-104	Universal Mounting Bracket
Z-SMA	AM/SM to AM Retrofit Mounting Bracket
ZG-AMA	Crank arm Adaptor Kit
AV8-25	Universal Shaft Extension
ZG-JSA (-1, 2, 3)	Jackshaft Adaptors for Hollow Jackshafts
ZS-100	Weather Shield - Steel
ZS-150	Weather Shield - Polycarbonate
ZS-260	Explosion Proof Housing
ZS-300 (-1) (-5)	NEMA 4X Housing
Tool-06	8 mm & 10 mm Wrench
S1A, S2A	Auxiliary Switch (es)
P370	Shaft Mount Auxiliary Switch
P...A	Feedback Potentiometers
SGA24	Min positioners in NEMA 4 housing
SGF24	Min positioners for flush panel mounting
ADS-100	Analog to Digital Switch
NSV24 US	Battery Back-Up Module
ZG-X40	Transformer

NOTE: When using AMX24-LON... actuators, only use accessories listed on this page.

Typical Specification

Proportional control damper actuators shall be electronic direct-coupled type, which require no crank arm and linkage and be capable of direct mounting to a shaft up to 1.05" diameter. Actuators shall have brushless DC motor technology and be protected from overload at all angles of rotation. Actuators shall have reversing switch and manual override on the cover. Run time shall be constant and independent of torque. Actuators shall be cULus listed, have a 5-year warranty, and be manufactured under ISO 9001 International Quality Control Standards. Actuators shall be as manufactured by Belimo.

Wiring Diagrams

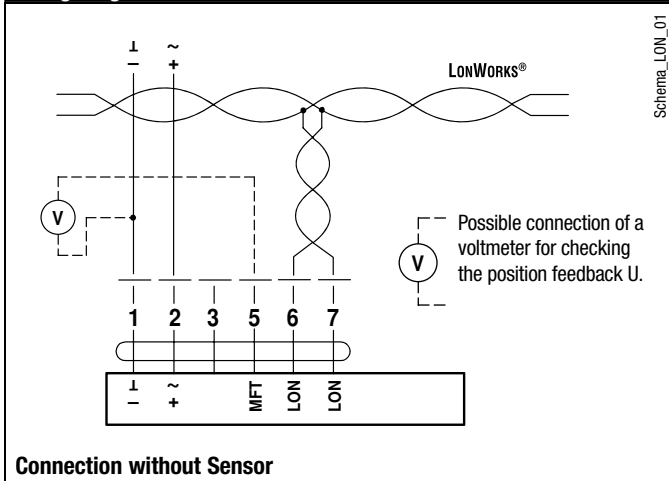

Connection without Sensor

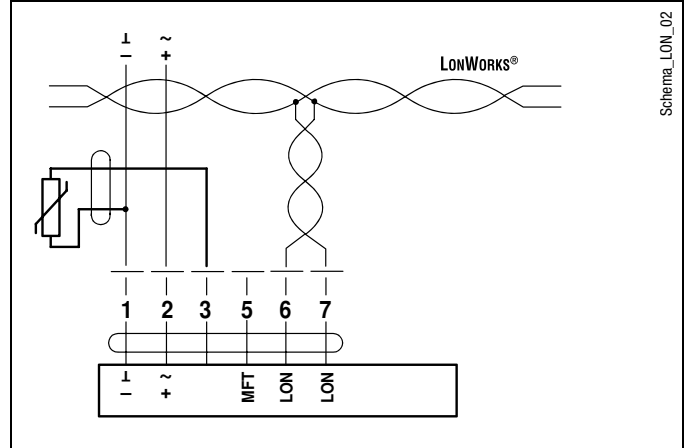

Sensor scaling:

The sensors can be scaled with the sensor plug-in (sensor table).

Sensor	Temperature range	Resistance range	Resolution
Ni1000	-28 ... +98°C	850 ... 1600 Ω	1 Ω
PT1000	-35 ... +155°C	850 ... 1600 Ω	1 Ω
NTC	-10 ... +160°C (depending on type)	200 ... 60 kΩ	1 Ω

Connection with Passive Sensor, e.g. Pt1000, Ni1000, NTC

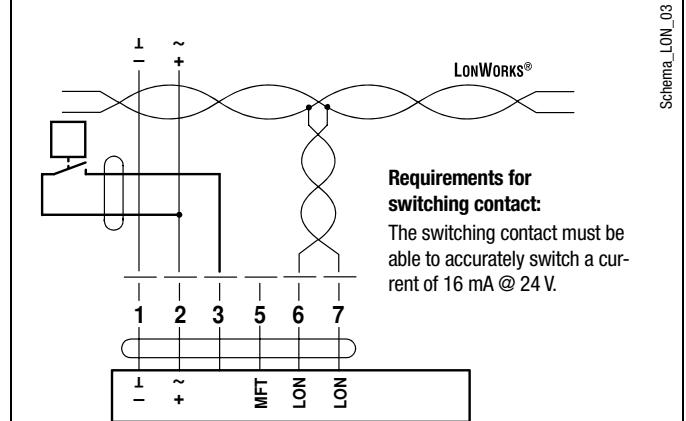

Requirements for switching contact:

The switching contact must be able to accurately switch a current of 16 mA @ 24 V.

Connection with Switching Contact, e.g. Δp-monitor

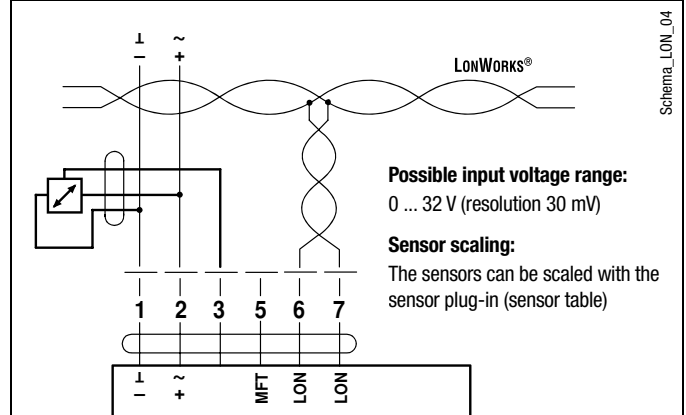

Possible input voltage range:
0 ... 32 V (resolution 30 mV)

Sensor scaling:

The sensors can be scaled with the sensor plug-in (sensor table)

Connection with Active Sensor, e.g. 0...10 V @ 0...50° C

Functional Profile according to LonMARK®

The LON-capable damper actuator is certified by LonMARK®. The actuator functions are supplied with the LonWorks® network as standardized network variables according to LonMARK®. The Node Object #0, the Damper Actuator Object #8110 and the Open Loop SensorObject #1 are implemented in the actuator.

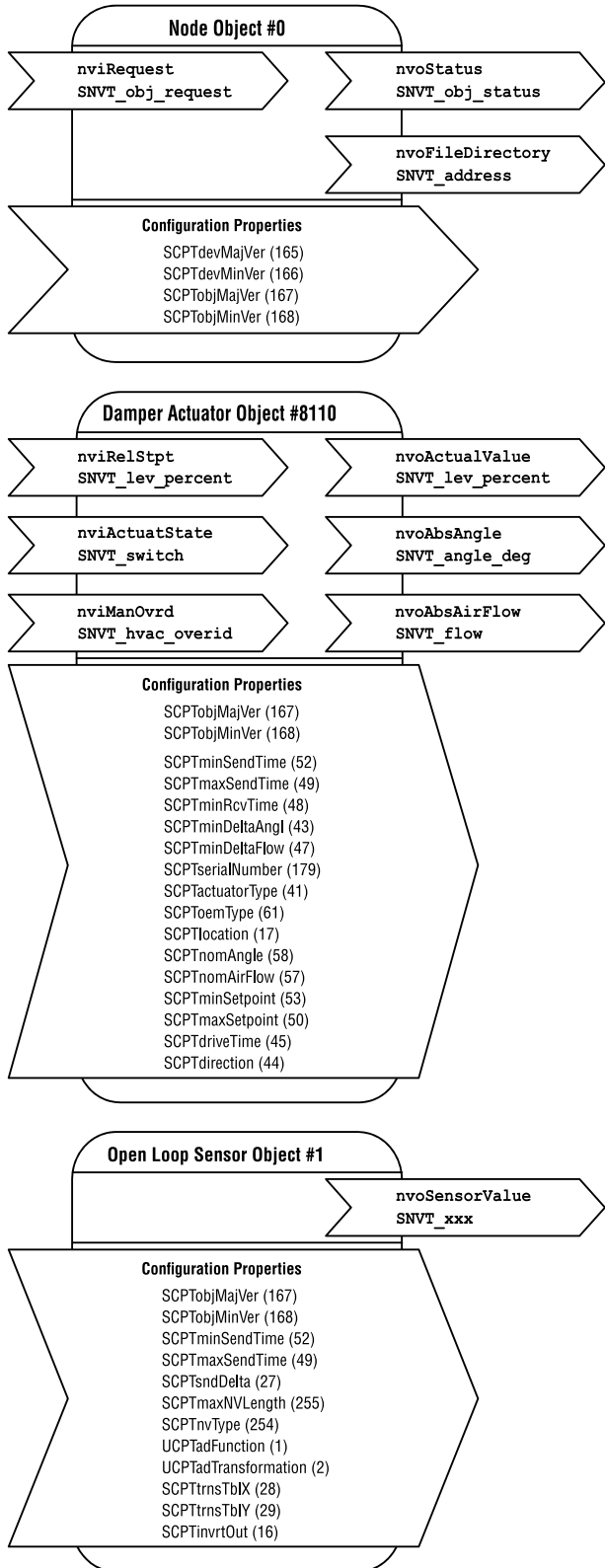

Node object #0

The node object contains the object status and object request functions.

- nviRequest** (SNVT_obj_request)
Input variable for requesting the status of a particular object in the node.
- nvoStatus** (SNVT_obj_status)
Output variable that outputs the current status of a particular object in the node.
- nvoFileDirectory** (SNVT_address)
Output variable that shows information in the address range of the Neuron chip.

Damper actuator object #8110

The actuator object is used to map the functions of the MP actuators to the LONWORKS® network.

- nviRelStpt** (SNVT_lev_percent)
The nominal position is assigned to the actuator via this input variable. This variable is normally linked to the output variable of an HVAC controller.
- nviActuateState** (SNVT_switch)
A preset position is assigned to the actuator via this input variable. Note on priority: The last variable that was active, either nviActuatorState or nviRelStpt, has priority.
- nviManOvrld** (SNVT_hvac_overid)
These input variables can be used to manually override the actuator into a particular position.
- nvoActualValue** (SNVT_lev_percent)
This output variable shows the current actual position of the actuator and can be used for control circuit feedback or for displaying positions.
- nvoAbsAngle** (SNVT_angle_deg)
This output variable shows the current angle of rotation of the actuator or the valve and can be used to display the position or for service purposes.

nvoAbsAirFlow (SNVT_flow)
This output variable is inactive with the SR24ALON-5 rotary actuator and shows a constant value of 65535 (this variable is only active in conjunction with LON-capable VAV controllers).

Open loop sensor object #1

A sensor can be connected to the rotary actuator. A passive resistance sensor (e.g. Ni1000), an active sensor (output 0 ... 32 V) or a switch (on/off) can be connected. The open loop sensor object transfers the measured sensor values to the LONWORKS® network.

nvoSensorValue (SNVT_xxx)
This output variable shows the current sensor value. Depending on the connected sensor, the output variable can be configured via the sensor plug-in and specifically adapted to the system.

The SNVT_... can be configured as:

SNVT_temp_p	SNVT_lev_percent	SNVT_lux
SNVT_temp	SNVT_abs_humid	SNVT_press_p
SNVT_switch	SNVT_enthalpy	SNVT_smo_obscur
SNVT_flow	SNVT_ppm	SNVT_power
SNVT_flow_p	SNVT_rpm	SNVT_elec_kwh

Notes

Detailed information on the functional profiles can be found on the website of LonMARK® (www.lonmark.org).



1 Direction of rotation switch	
Switching over	Direction of rotation changes
2 Pushbutton and green LED display	
Off	No voltage supply or malfunction
Green, on	Operation
Press button	Switches on angle of rotation adaption followed by standard operation
3 Service button for commissioning LONWORKS® and yellow LED display for the LON status	
Off	The SR24ALON-5 rotary actuator is connected and ready for operation in the LONWORKS®network.
Yellow, on	No application software is loaded in the SR24ALON-5.
Yellow, flashing (flashing interval 2 seconds)	The SR24ALON-5 is ready for operation but not integrated in the LONWORKS® network (unconfigured).
Other flashing codes	A fault is present in the SR24ALON-5.
Press button	Service Pin Message is sent to the LONWORKS®network.
4 Gear disengagement switch	
Press button	Gear disengaged, motor stops, manual operation possible
Release button	Gear engaged, synchronisation starts, followed by standard operation
5 Service plug	
For connecting MFT parameterizing and service tools	